

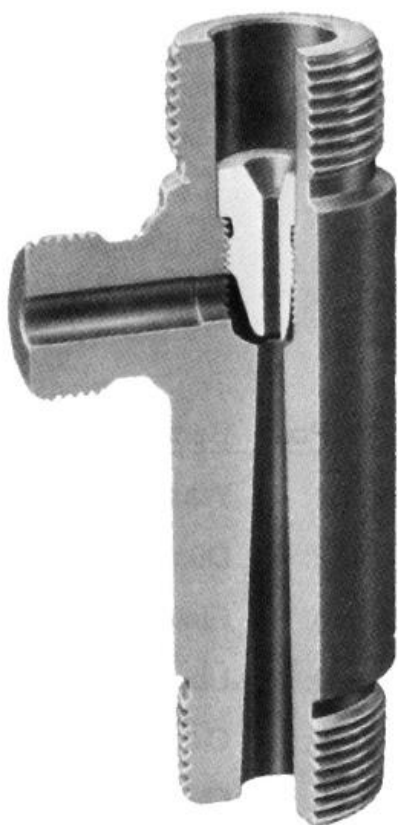

## Water Jet Pump P20

DN 10 ... DN 80



up to DN 10



from DN 25

- For acids and alkalis
- For conveying and mixing
- Variable materials and nozzle inserts

D-EN-P20\_20200128



## Water Jet Pump P20

DN 10 ... DN 80

### Function

The basic principle of the water jet pump is that the propellant liquid emerges from a nozzle and entrains and accelerates the liquid or gaseous medium from the suction line. The result of this process is a mixture of the driving and the sucked medium. The propellant quantity is a function of the propellant pressure and nozzle bore. The amount drawn is shown in the diagrams. The specified services are only guidelines and change depending on the operating conditions.

### Applications

Water-jet liquid pumps can be used where there is liquid under pressure as the propellant. They are used for pumping out pits, for conveying and mixing chemical waste water, for adding acids or alkalis in water treatment, etc. They are self-priming and have no mechanically moving parts.

Since the P20 water jet pumps are supplied in different materials, they can be used where the materials meet the given requirements.

### Design

DN 10 – DN 20 with male threads  
DN 25 – DN 50 with screwing  
DN 65 – DN 80 with bonded nozzle

### Technical data

Available materials	PVC, PP, PVDF
permissible operating temperature	PVC 0 to +60°C PP -20 to +80°C PVDF -20 to +120°C
Operating pressure	Max. 10 bar at 20°C

### Important instructions!

Technical changes and errors reserved.

Pictures can be similar.

The operating instructions belonging to this device must be observed! Download at [www.schmidt-messtechnik.com](http://www.schmidt-messtechnik.com).



## Water Jet Pump P20

DN 10 ... DN 80

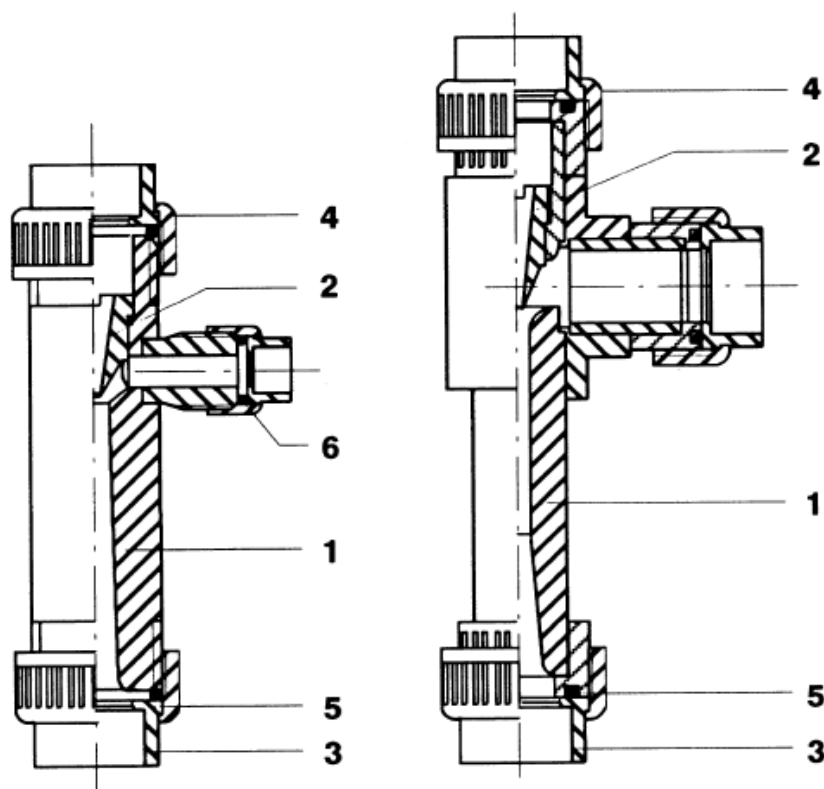

up to DN 10

from DN 25

from DN 25 onwards, delivery is only possible with a nozzle

Pos.	Description
1.	Water jet pump
2.	Nozzle
3.	Union end
4.	Cap nut
5.	O-ring
6.	O-ring

### Ordering number

da	DN	PVC	PP	PVDF
16	10	17.002.118	17.002.127	17.002.136
20	15	17.002.119	17.002.128	17.002.137
25	20	17.002.120	17.002.129	17.002.138
32	25	17.002.121	17.002.130	17.002.139
40	32	17.002.122	17.002.131	17.002.140
50	40	17.002.123	17.002.132	17.002.141
63	50	17.002.124	17.002.133	17.002.142
75	65	17.002.125	17.002.134	17.002.143
90	80	17.002.126	17.002.135	17.002.144

Please specify nozzle bore!



## Water Jet Pump P20

DN 10 ... DN 80

### Dimensions

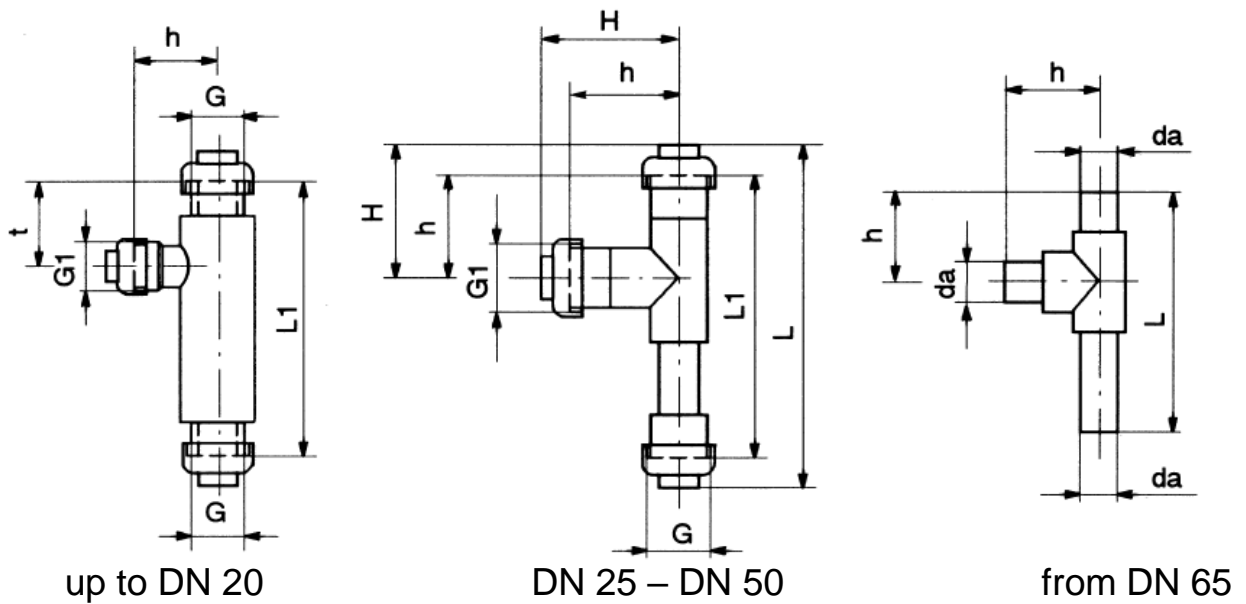

Type	da	DN	G	G1	L	L1	t	H	h
P 20.10 - 1,5	16	10	R 3/4"	R 3/4"	-	110	40	-	35
P 20.10 - 2,0									
P 20.15 - 2,0	20	15	R 1"	R 3/4"	-	110	40	-	35
P 20.15 - 3,0									
P 20.15 - 4,0									
P 20.20 - 3,0	25	20	R 1 1/4"	R 3/4"	-	145	45	-	45
P 20.20 - 4,5									
P 20.20 - 6,0									
P 20.25 - 2,5	32	25	R 1 1/2"	R 1 1/2"	245	195	-	96	71
P 20.25 - 4,0									
P 20.25 - 5,0									
P 20.32 - 3,0	40	32	R 2"	R 2"	297	239	-	116	87
P 20.32 - 4,5									
P 20.32 - 6,0									
P 20.40 - 3,5	50	40	R 2 1/4"	R 2 1/4"	369	301	-	139	105
P 20.40 - 5,5									
P 20.40 - 7,5									
P 20.50 - 5,0	63	50	R 2 3/4"	R 2 3/4"	433	351	-	169	128
P 20.50 - 7,0									
P 20.50 - 9,0									
P 20.65 - 6,5	75	65	-	-	388	-	-	-	115
P 20.65 - 9,0									
P 20.65 - 11,5									
P 20.80 - 8,0	90	80	-	-	465	-	-	-	149
P 20.80 - 11,0									
P 20.80 - 14,0									

D-EN-P20\_20200128



## Water Jet Pump P20

DN 10 ... DN 80

### Performance chart for Water Jet Pump P 20.10

suction medium: water

Type P 20.10-1,5

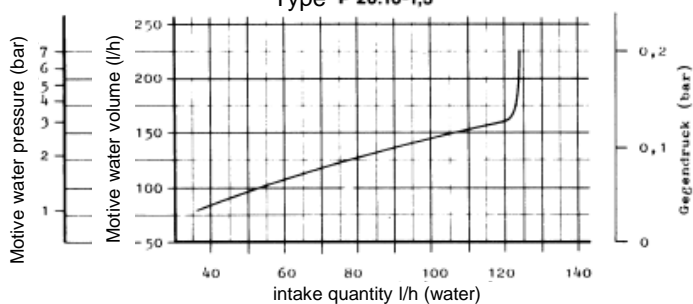

suction medium: air

Type P 20.10-1,5

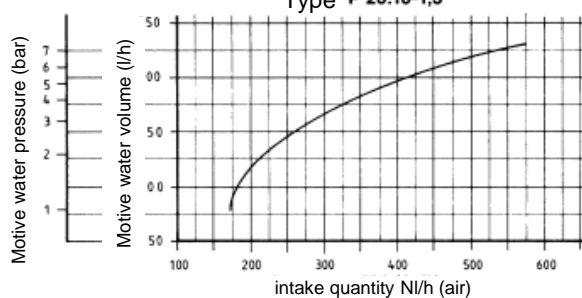

Type P 20.10-2,0

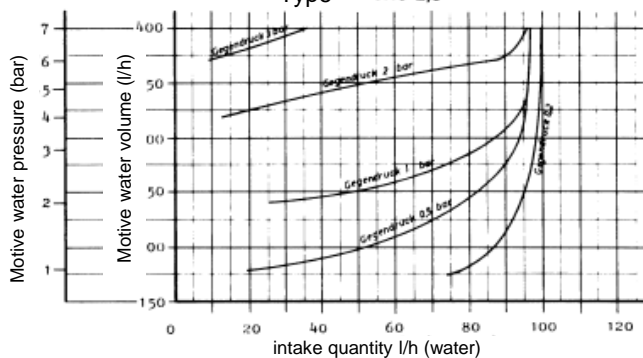

Type P 20.10-2,0

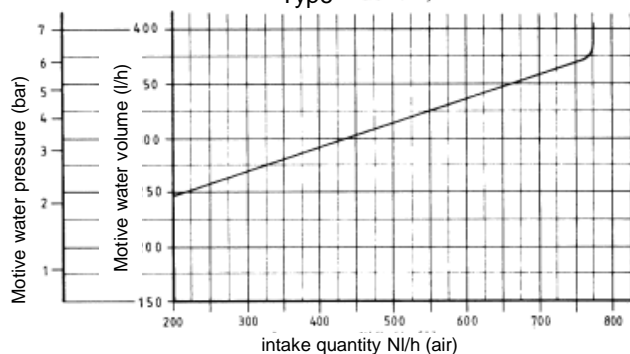



## Water Jet Pump P20

DN 10 ... DN 80

### Performance chart for Water Jet Pump P 20.15

suction medium: water

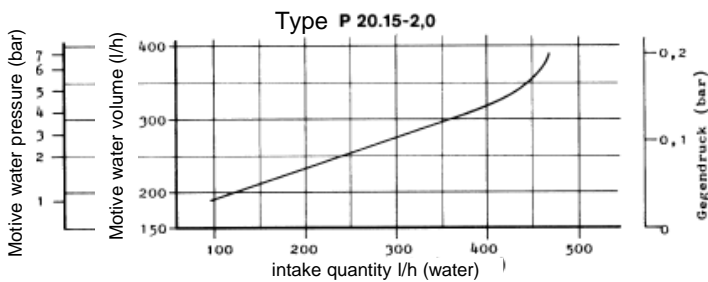

suction medium: air

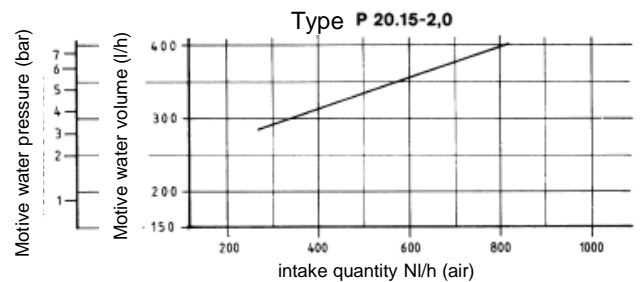

Type P 20.15-3,0

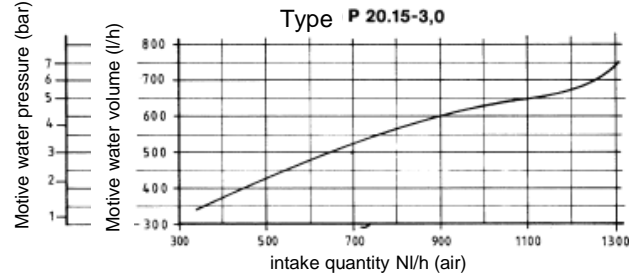
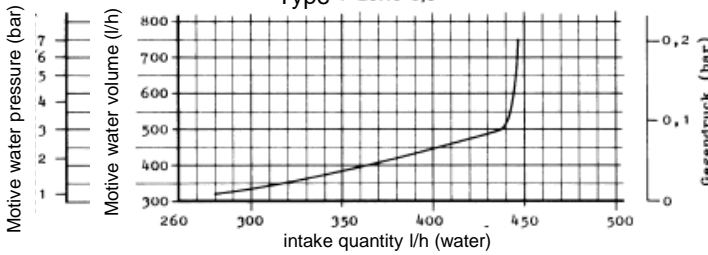

Type P 20.15-4,0

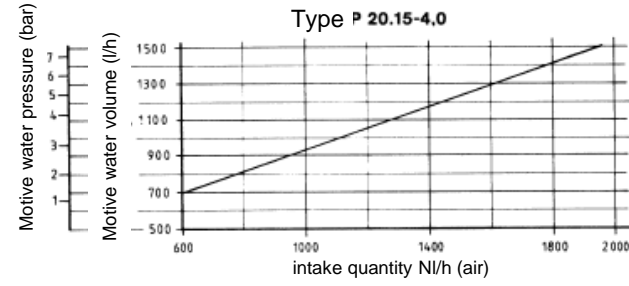
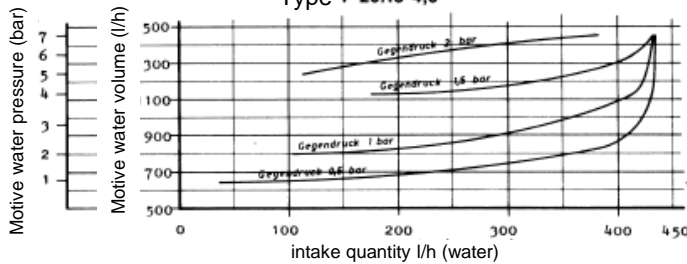



## Water Jet Pump P20

DN 10 ... DN 80

### Performance chart for Water Jet Pump P 20.20

suction medium: water

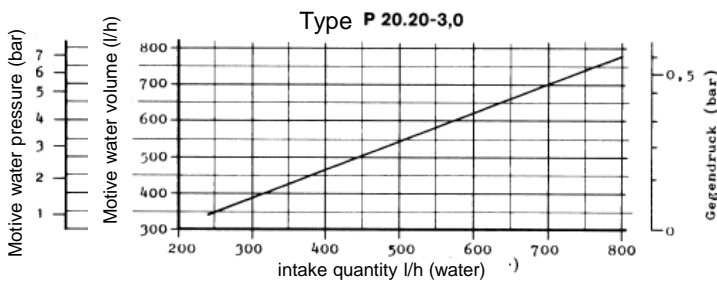

suction medium: air

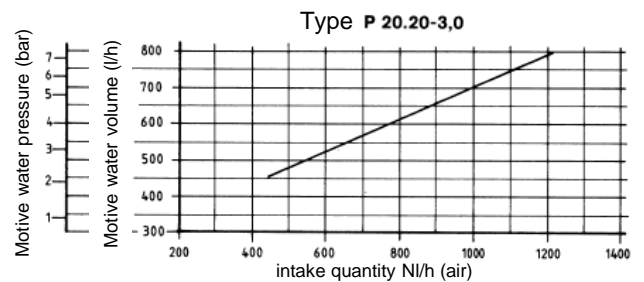

**Type P 20.20-4,5**

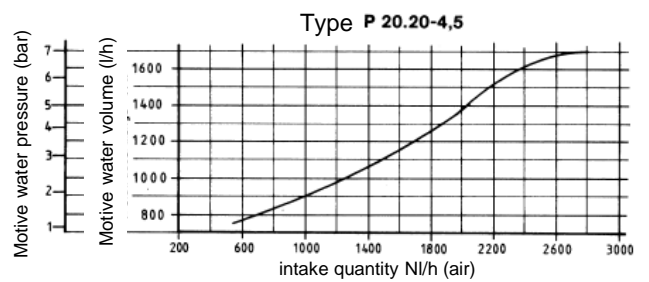
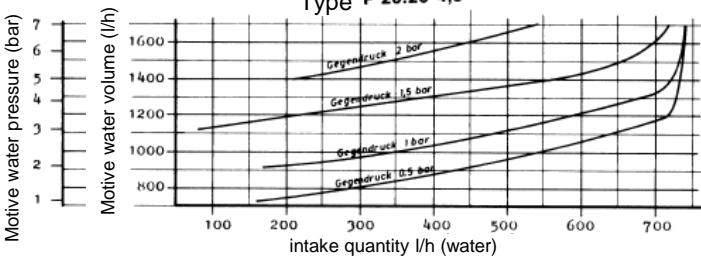

**Type P 20.20-6,0**

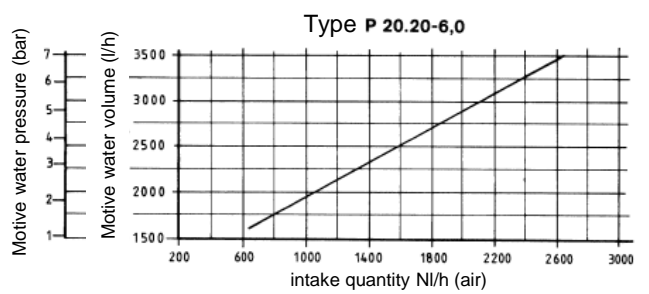
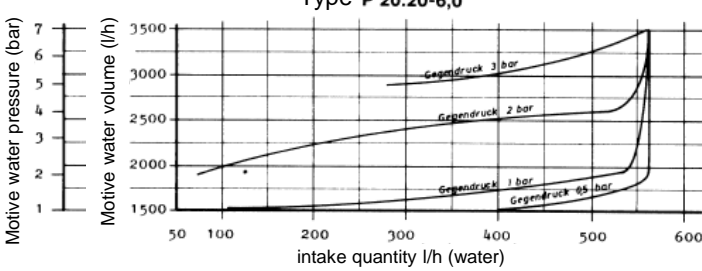





## Water Jet Pump P20

DN 10 ... DN 80

### Performance chart for Water Jet Pump P 20.32

suction medium: water

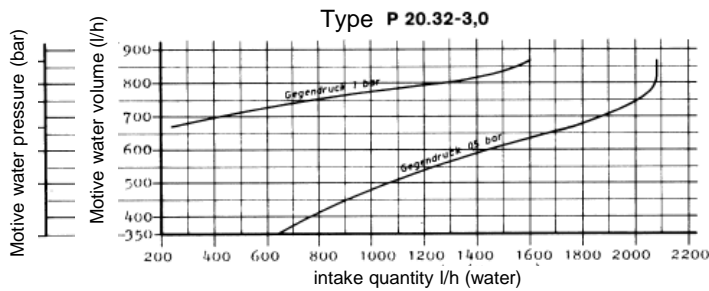

suction medium: air

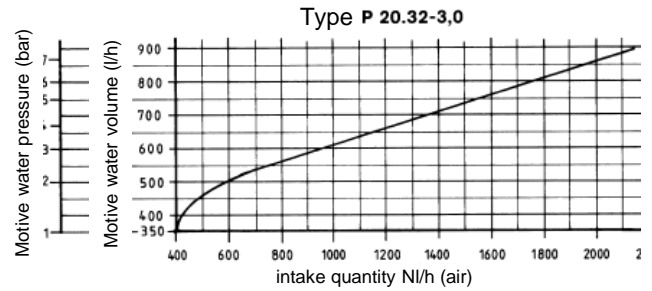

Type P 20.32-4,5

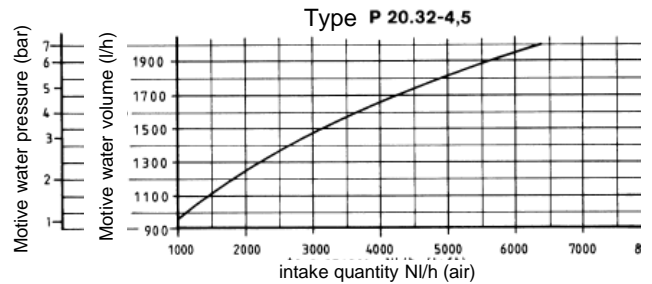
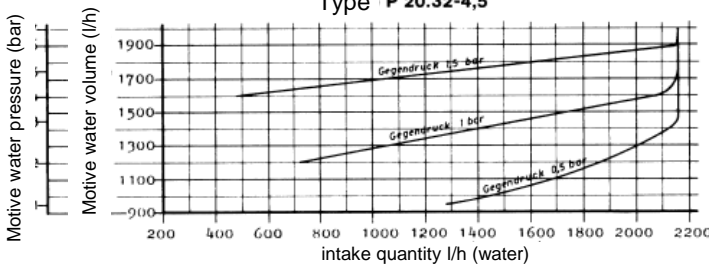

Type P 20.32-6,0

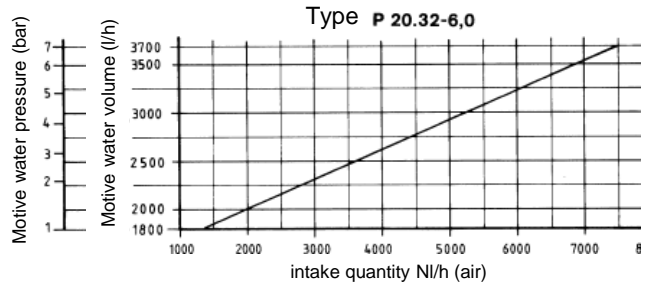
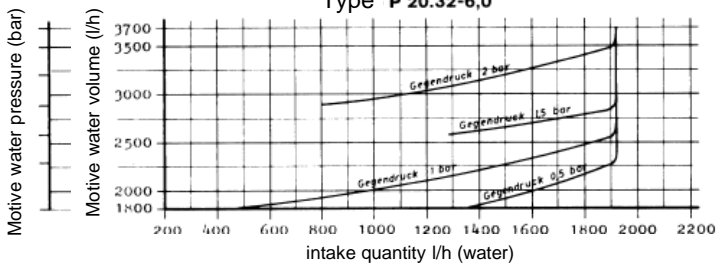





## Water Jet Pump P20

DN 10 ... DN 80

### Performance chart for Water Jet Pump P 20.40

suction medium: water

Type P 20.40-3,5

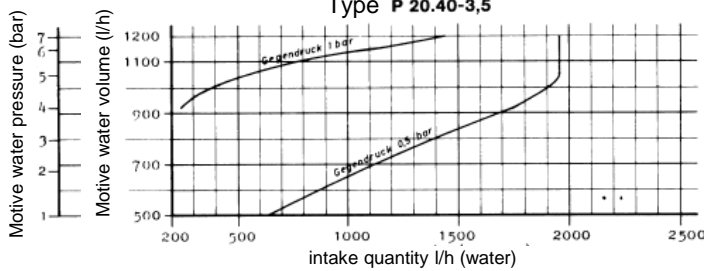

suction medium: air

Type P 20.40-3,5

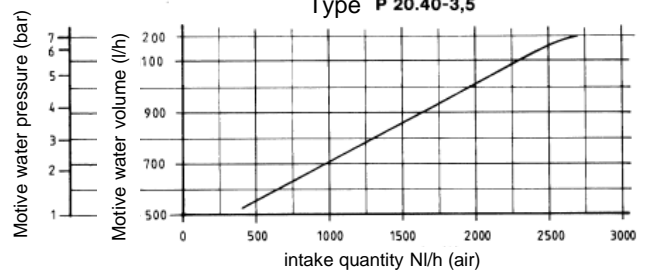

Type P 20.40-5,5

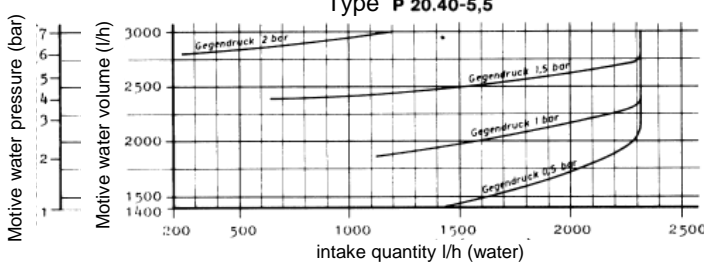

Type P 20.40-5,5

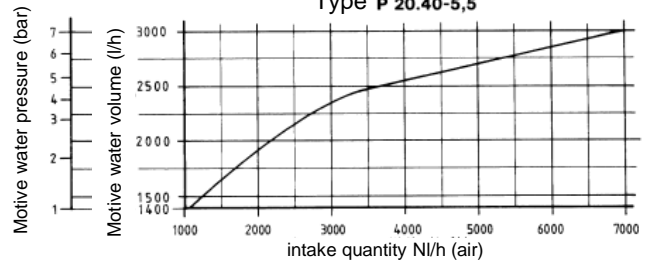

Type P 20.40-7,5

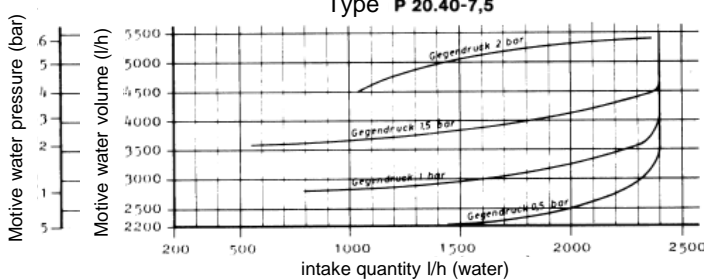

Type P 20.40-7,5

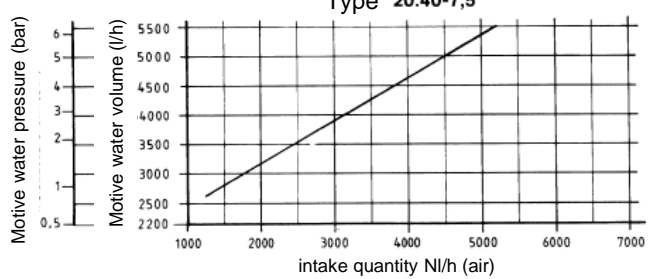



## Water Jet Pump P20

DN 10 ... DN 80

### Performance chart for Water Jet Pump P 20.50

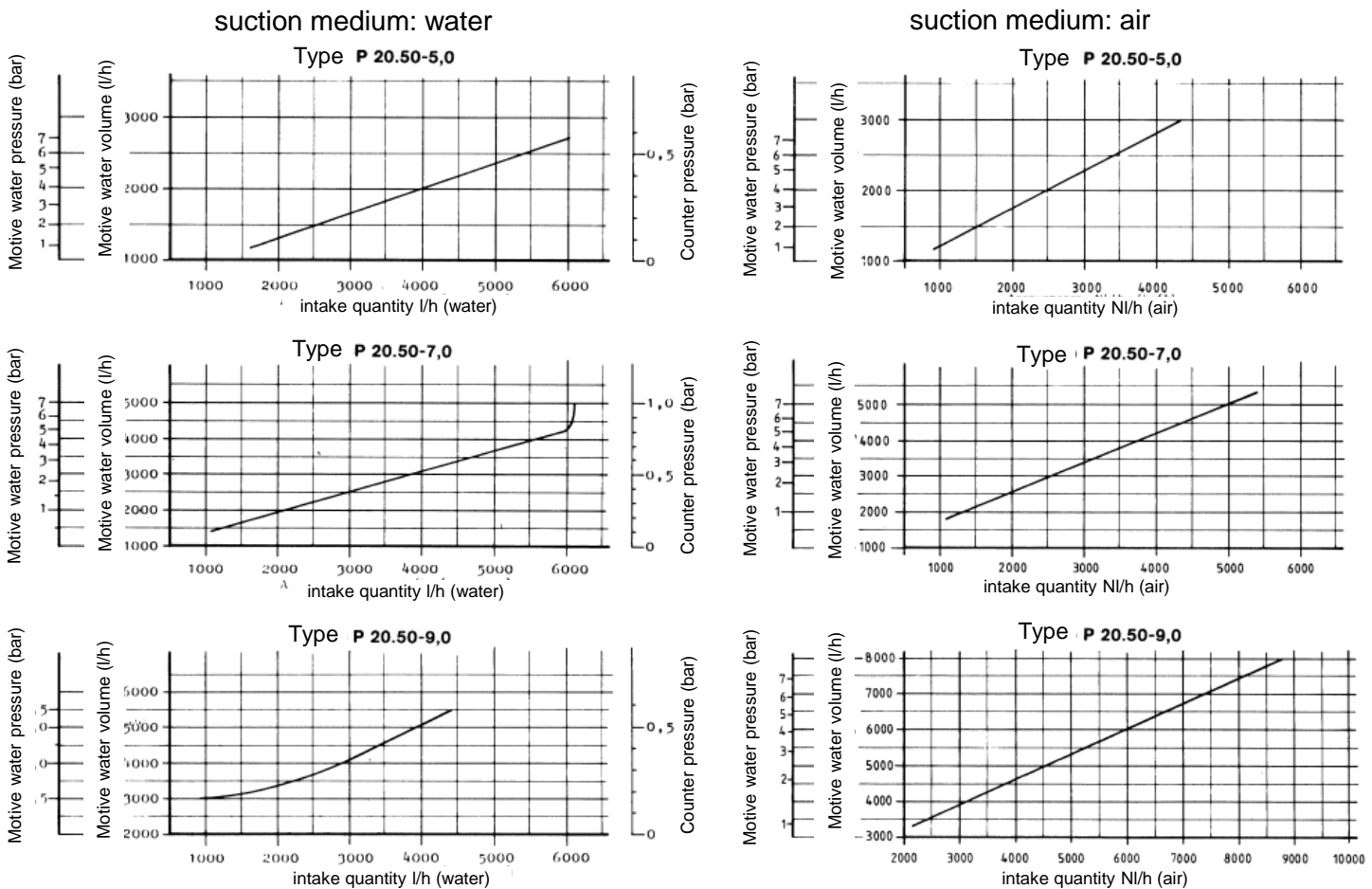



## Water Jet Pump P20

DN 10 ... DN 80

### Performance chart for Water Jet Pump P 20.65

suction medium: water

Type P 20.65-6,5

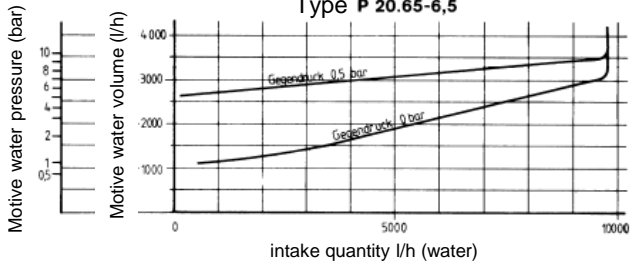

suction medium: air

Type P 20.65-6,5

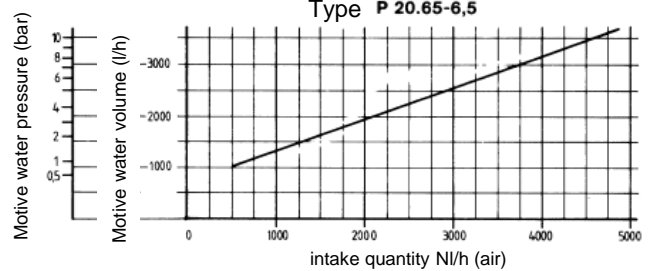

Type P 20.65-9,0

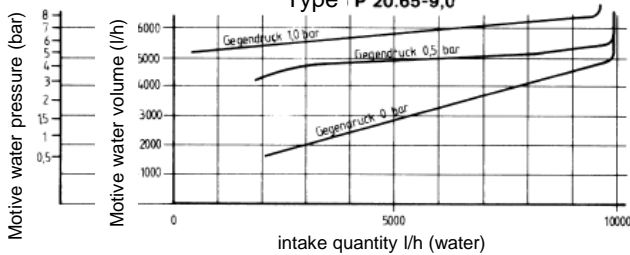

Type P 20.65-9,0

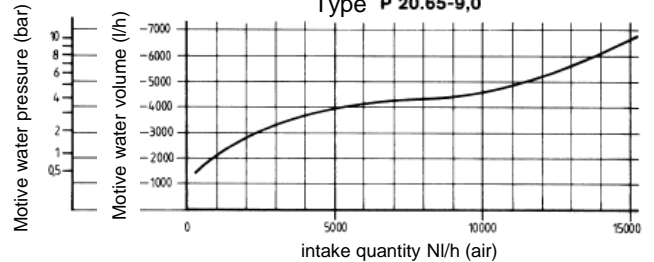

Type P 20.65-11,5

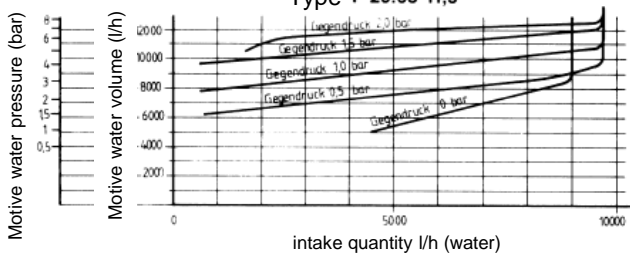

Type P 20.65-11,5

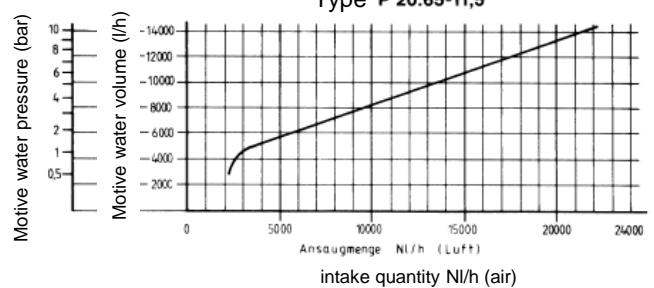



## Water Jet Pump P20

DN 10 ... DN 80

### Performance chart for Water Jet Pump P 20.80

suction medium: water

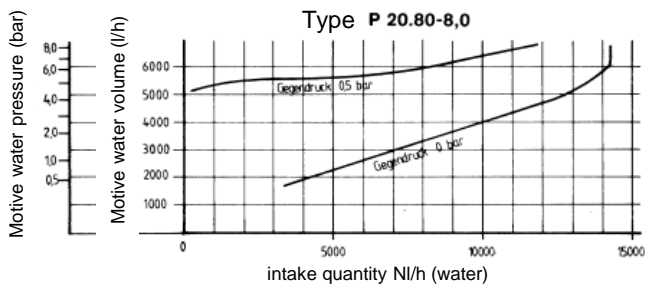

suction medium: air

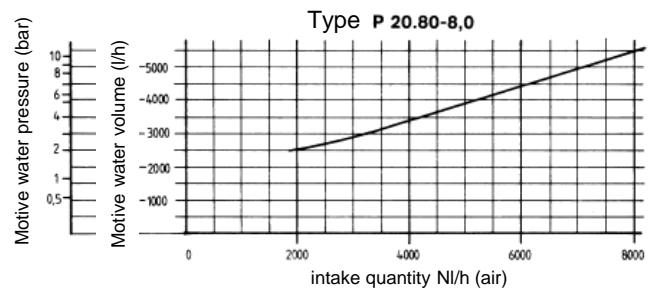

**Type P 20.80-11,0**

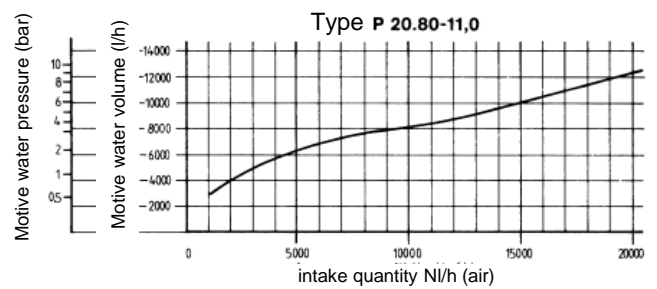
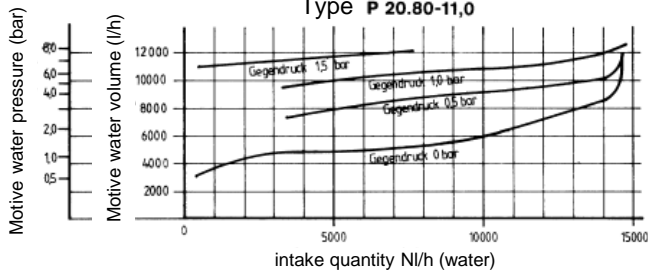

**Type P 20.80-14,0**

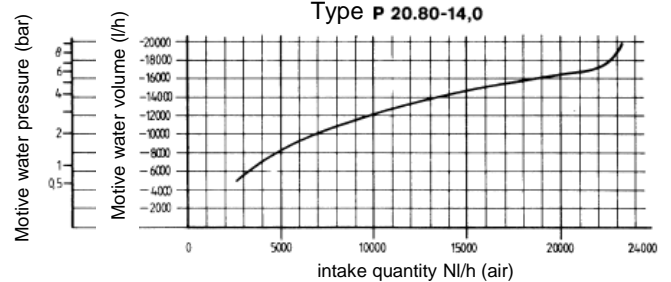
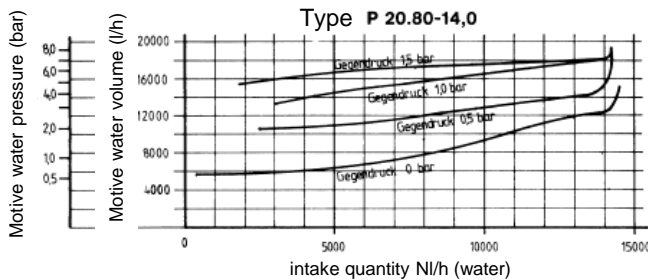



## Water Jet Pump P20

DN 10 ... DN 80

### Installation instructions

- It is recommended to install the water jet pump between two detachable pipe connections. For the eventual subsequent expansion, it is advantageous to provide shut-off devices.
- Calming sections of at least 5 x DN before and after the pump must be provided.
- It is recommended to install a variable area flow meter in the suction line in order to obtain information on the suction power of the pump.
- It is advantageous to install pressure gauges before and after the water starch pump for reading the upstream and back pressure.
- The suction time is significantly reduced by installing a check valve in the suction line.
- Inlets and outlets must have at least the nominal diameter of the pump.
- An exact metering of the propellant and intake flow is possible by installing throttle valves.

### Error

Errors can occur if e.g. the process water pressure fluctuates or is too low if the back pressure is too high or if the nozzles are dirty and clogged.



## Water Jet Pump P20

DN 10 ... DN 80

Max. achievable vacuum for water jet pumps P 20, DN 10 – DN 80

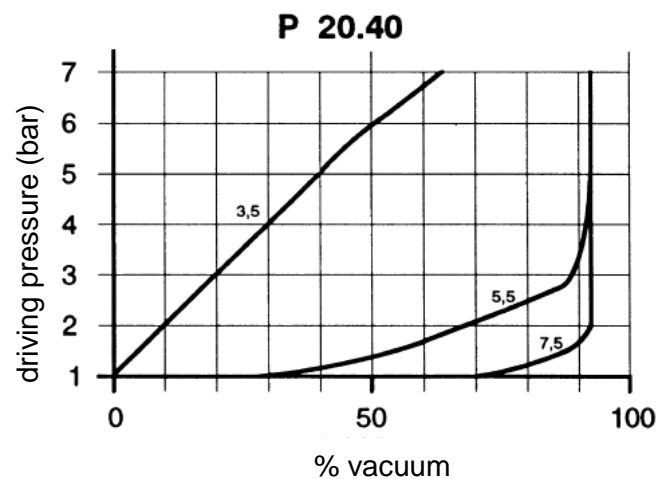
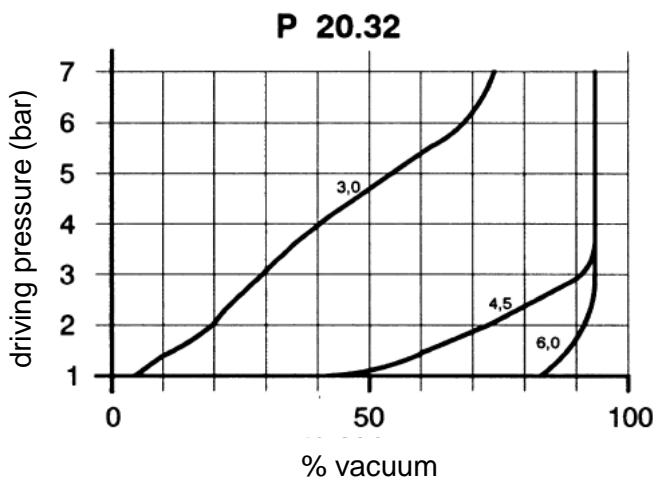
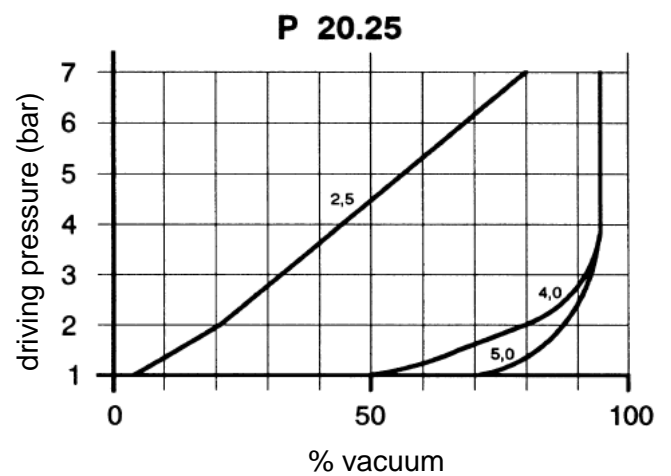
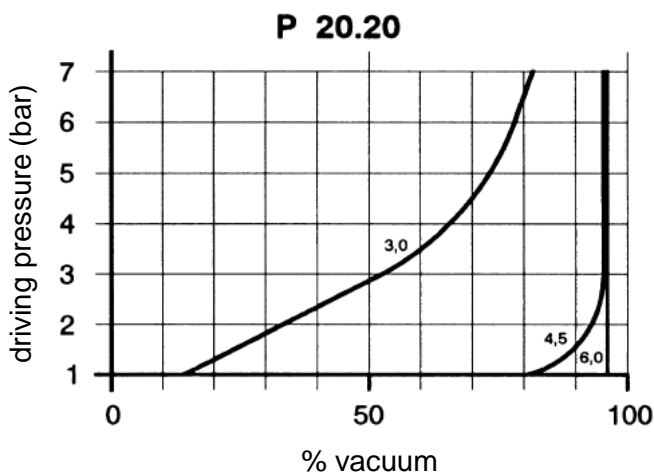
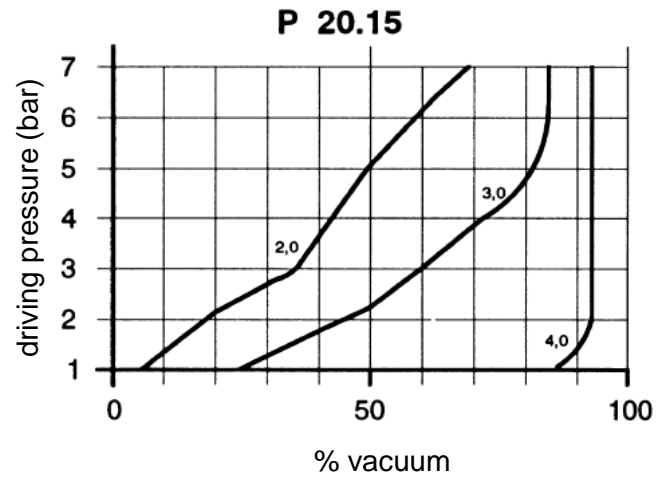
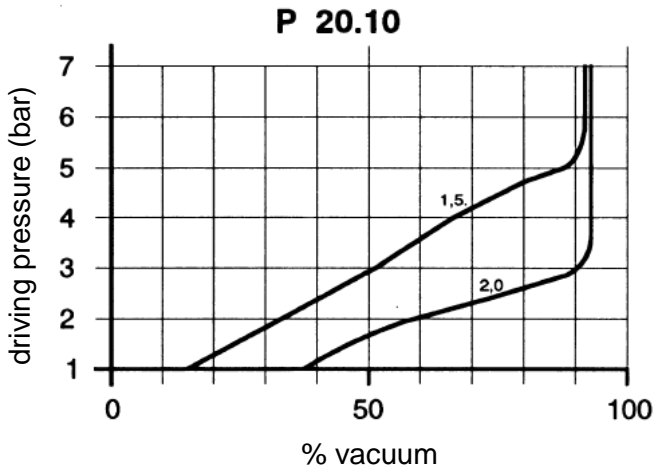

D-EN-P20\_20200128



## Water Jet Pump P20

DN 10 ... DN 80

Max. achievable vacuum for water jet pumps P 20, DN 10 – DN 80

**P 20.50**

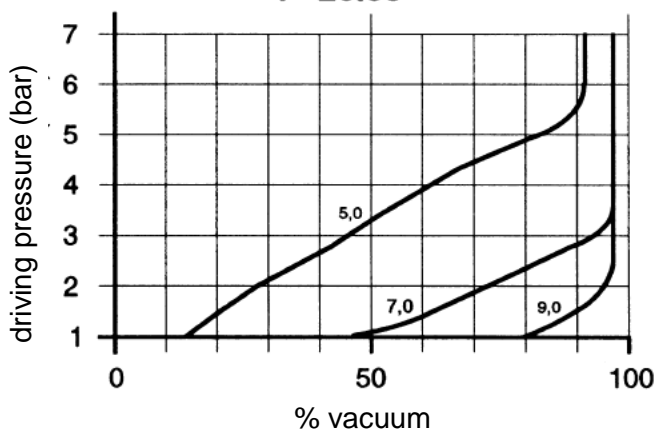

Note: The information on the characteristic curve (e.g. 3.0) is the respective diameter of the nozzle bore.

**P 20.65**

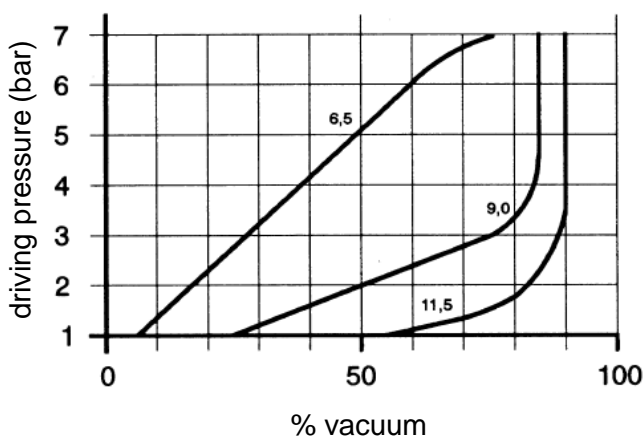

**P 20.80**

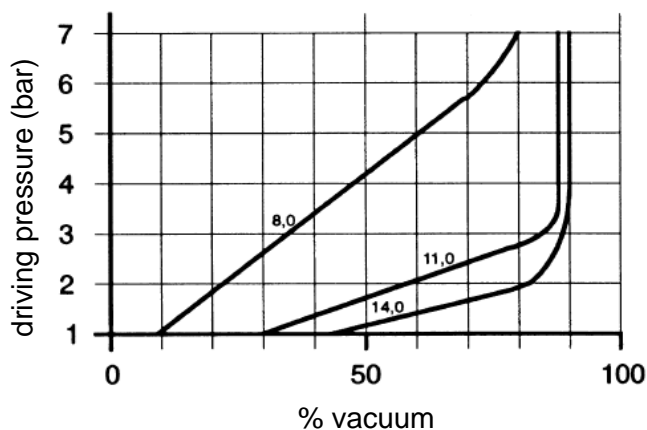





## Water Jet Pump P20

DN 10 ... DN 80

### Design of a water jet pump

Required information		Example		Data acc. to diagram	
Motive water pressure	bar	3	bar	3	bar
Driving water volume	l/h	1200	l/h	1180	l/h
Suction volume	l/h	550	l/h	1150	l/h
Suction medium		HCl 30%		H <sub>2</sub> O	
Backpressure	bar	1	bar	1	bar

The suction volume must be reduced to the desired value.

Example:

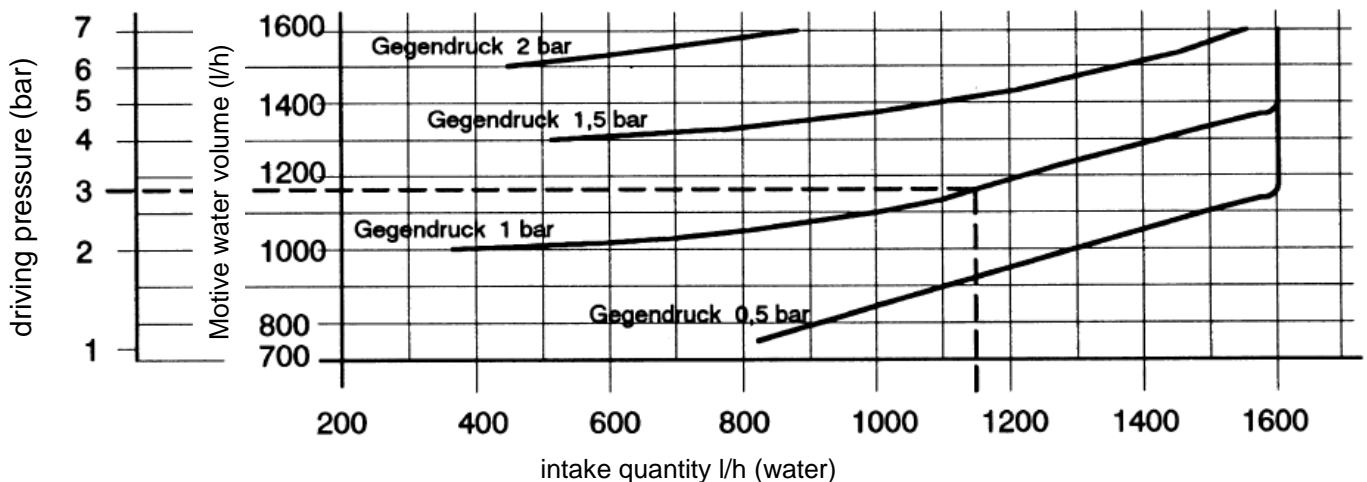
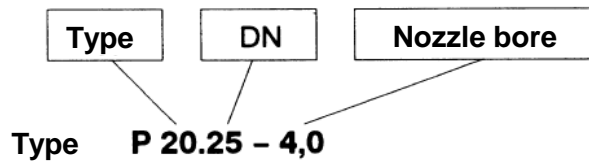

### Attention:

Do not use a diaphragm valve to adjust the suction quantity, because the vacuum can cause the diaphragm to stick to the seat. We recommend using the throttle sleeve V251.

D-EN-P20\_20200128