



Bi-Metal Thermometer Type 30

Industrial thermometer in a bayonet ring housing with rotatable screw-in pin



D-EN-Type30-20200212

- Precision bimetal thermometer, axial, DIN 16 204
- Temperature range: -60 ... +500 °C
- Material: stainless steel or sheet steel



Bi-Metal Thermometer Type 30

Industrial thermometer in a bayonet ring housing with rotatable screw-in pin

Features

- Precision bimetal thermometer, axial, DIN 16 204
- Temperature range: - 60 ... + 500 ° C
- Accuracy: Class 1 according to DIN 16 203
- Material: stainless steel or sheet steel
- Additional devices: limit contacts, oil damping
- Process connection: rotatable screw-in spigot for installation in protective tubes

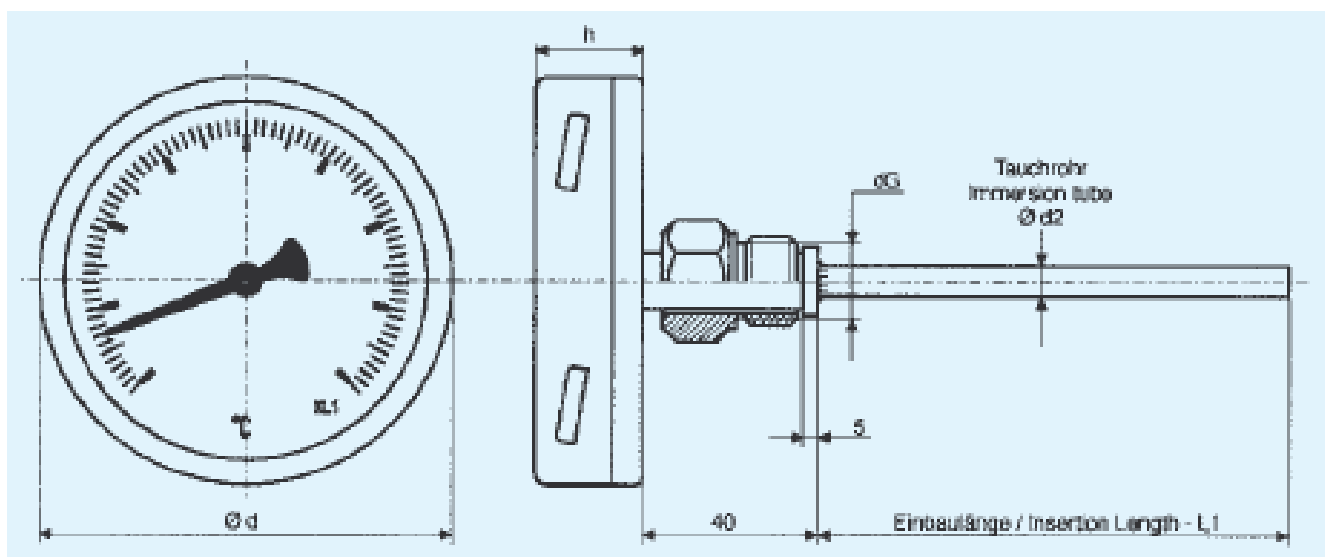

Housing dimensions		
Ordering code:		C
ød	height (h)	
63	20	3
80	24	4
100	28	5
160	28	3

Housing material	
Ordering code:	E
Stainless steel 1.4301	1
Sheet steel	2

D-EN-Type30-20200212



Bi-Metal Thermometer Type 30

Industrial thermometer in a bayonet ring housing with rotatable screw-in pin

Standard measuring ranges		
Ordering code	F	G
-40...+40 °C	4	9
-40...+60 °C	5	0
-30...+50 °C	5	2
-20...+40 °C	5	3
-20...+60 °C	5	4
0...+60 °C	5	8
0...+80 °C	5	9
0...+100 °C	6	0
0...+120 °C	6	1
0...+160 °C	6	2
0...+200 °C	6	3
0...+250 °C	6	4
0...+300 °C	6	5
0...+350 °C	6	6
0...+400 °C	6	7
0...+500 °C	6	8
Special range on request	9	9

Thread	
Ordering code:	N
G 1/2"...SW27	1
G 3/4"...SW32	2
G 1"...SW41	3
M18 x 1,5...SW24	6
M20 x 1,5...SW27	7
M24 x 1,5...SW32	8
M27 x 2...SW32	9

Material for dip tube and thread	
Ordering code	①
Brass	1
Stainless steel, 1.4571	3

Accessories	
Ordering code:	H
Without accessories	0
Low-action execution	1
With inductive contact	3
With electronic contacts	4
Mark pointer	5
Drag pointer	6
Silicon oil filling (up to 250 °C)	7
Glycerine filling (up to 199 °C)	8
Contact version with transformer oil filling on request	

D-EN-Type30-20200212



Bi-Metal Thermometer Type 30

Industrial thermometer in a bayonet ring housing with rotatable screw-in pin

Contact functions		
Ordering code	J	K
Single contact		
Normally open contact	X	1
Normally closed contact	X	2
Changeover contact	X	3
Bifurcated contact		
2 x normally open contact	1	1
2 x normally closed contact	2	2
1. NOC / 2. NCC	1	2
1. NCC / 2. NOC	2	1

Electrical connection	
Ordering code	I
Without	0
1 m connecting cable	1
socket	2

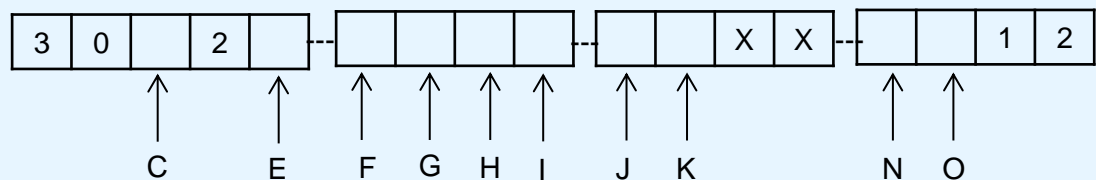

Ordering code:

To order, please fill in all empty spaces.

The relevant key figures for all vacancies can be found in the tables above.



Bi-Metal Thermometer Type 30

Industrial thermometer in a bayonet ring housing with rotatable screw-in pin

Installation suggestions for thermometers with loose union nut

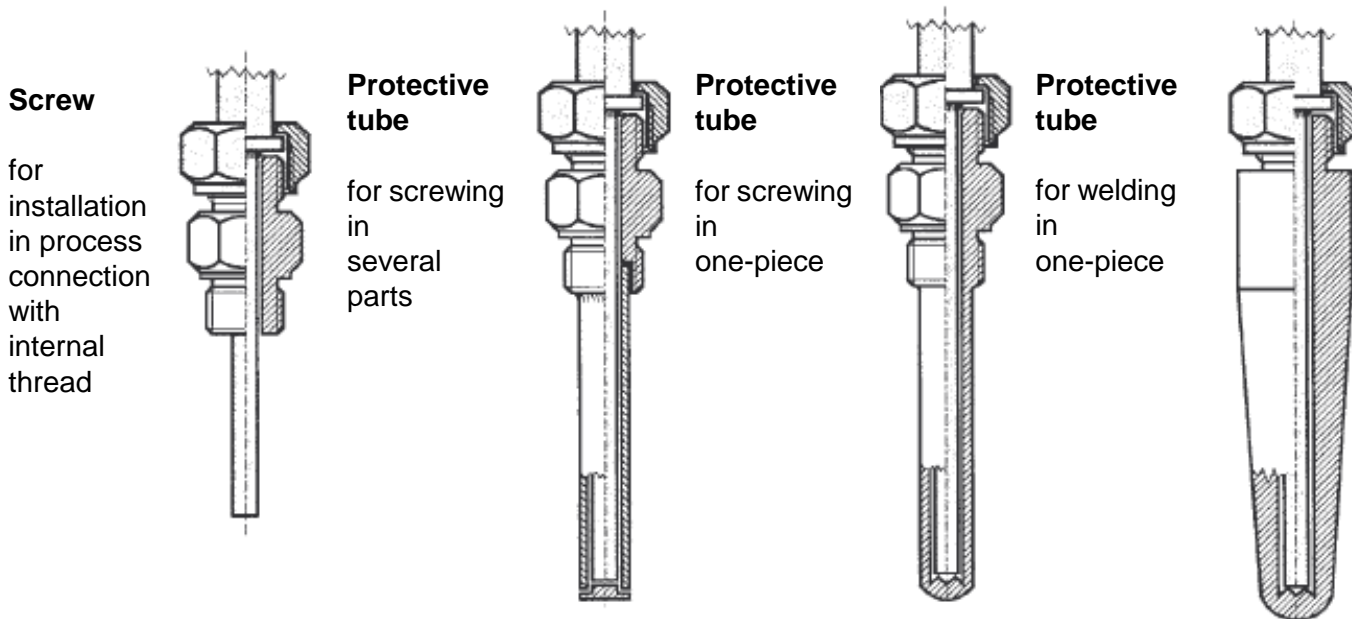

D-EN-Type30-20200212

Important instructions!

Technical changes and errors reserved. Pictures can be similar.

The operating instructions belonging to this device must be observed! Download at www.schmidt-messtechnik.com.