



Miniature Float Switch SMV-1

Miniature float switch for installation from top



D-EN-SMV-1-20190426

- Short length
- Switching function variable
- Cable length 5 m



Miniature Float Switch SMV-1

Miniature float switch for installation from top

Function

Miniature float switches work according to the proven float principle. A permanent magnet located in the float actuates a reed contact when the liquid level rises. By turning the float by 180°, the NC or NO function can be realized by the customer.

Application

Our miniature float switches are characterized by a compact, simple design, high reliability and a low price.

The switches can be used anywhere where liquid levels have to be monitored safely and signals have to be given to further processing facilities such as pumps and control devices.

Technical data	
Material	PVC
Switching power	0.5 A, 10 VA
Switching function	Normally open contact (NOC) or normally closed contact (NCC)
Operating pressure max.	2 bar
Temperature	-5°C...+60°C
Connecting cable	5 m
Contact	Reed contact
Density of the medium	0.8 kg/l min.



Miniature Float Switch SMV-1

Miniature float switch for installation from top

Dimensions

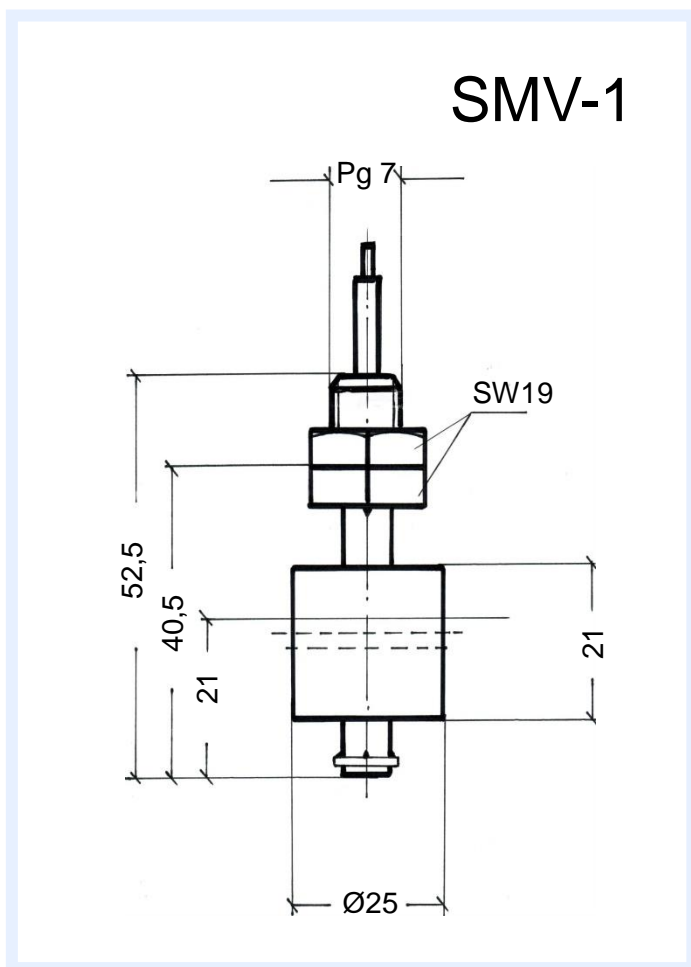

D-EN-SMV-1-20190426

Important instructions!

Technical changes and errors reserved.

Pictures can be similar.

The operating instructions belonging to this device must be observed! Download at www.schmidt-messtechnik.com.