



Flow Monitors DKME-1, viscosity compensated Float measuring principle for liquids



D-EN-DKME-20200526

- Universal orientation
- High reliability
- High switch accuracy
- Wide switch range



Flow Monitors DKME-1, viscosity compensated Float measuring principle for liquids

Features

- Universal orientation
- High reliability
- High switch accuracy
- Wide switch range
- Viscosity compensated
- Infinitely variable switch point adjustment by operator
- EX-version according to ATEX directive available
- UL Recognized version available
- High pressure resistance
- Threaded connection, special thread on request

Application

- Mechanical engineering
- Central lubrication
- Circulation lubrication
- Transformers

Installation information

The operating instructions for DKME-1 Module BASICS / ...ATEX must be observed!
Download: www.schmidt-messtechnik.de

Operating data	
Operating pressure, max.	250 bar (brass version), 300 bar (stainless steel version)
Pressure drop	0,02 – 0,4 bar
Viscosity range	30 cSt to 600 cST
Temperature max.	120°C (optional 160°C)
Measuring accuracy	±10% of full scale

Changed operating data apply to the device in explosion-proof design according to ATEX directive. Refer to the Operating Instructions for DKME-1 Module ATEX.
For UL Recognized devices, changed operating data apply. Refer to the Operating Instructions for DKME-1 Module BASICS.



Flow Monitors DKME-1, viscosity compensated Float measuring principle for liquids

Measuring ranges			
Type	Switch range for oil, density 0,9 kg/dm ³ (1)		
	[l/min]	[gph]	[gpm]
DKME-1/20	1 – 20	15,0 – 320,0	
DKME-1/40	4 – 40	60,0 – 630,0	
DKME-1/50	5 – 50	80,0 – 790,0	
DKME-1/60	8 – 60	130,0 – 950,0	
DKME-1/70	12 – 70		3,2 – 18,5
DKME-1/80	15 – 80		4,0 – 21,1

(1) The specified measuring- /switch ranges are valid for oils having a density of 0.9 kg/dm³ and a kinematic viscosity of 30 to 600 cSt, vertical installation of the device and flow direction from bottom to top.

Other installation positions or deviation from the operating densities and operating viscosities will increase the measurement error specified in the data sheet. Excessive operating viscosities will influence or may prevent function of the device.

Upon request, special scales for deviating media, different operating conditions and installation positions (only for devices which can be installed in any position) are available.

The specified switch values are switch-off points, i.e. switch values by decreasing flow.

Other measuring- /switch ranges are available upon request.

Materials		
Wetted parts:	Brass version	Stainless steel version
Spring	1.4571	1.4571
Gaskets	FKM (optional: NBR, EPDM) ⁽²⁾	FKM (optional: NBR, EPDM) ⁽²⁾
Magnets	Hard ferrite	Hard ferrite
Device body	Brass, nickel-plated	1.4571
All other wetted parts	Brass	1.4571

(2) Other gasket materials on request

D-EN-DKME-20200526



Flow Monitors DKME-1, viscosity compensated Float measuring principle for liquids

Technical drawing

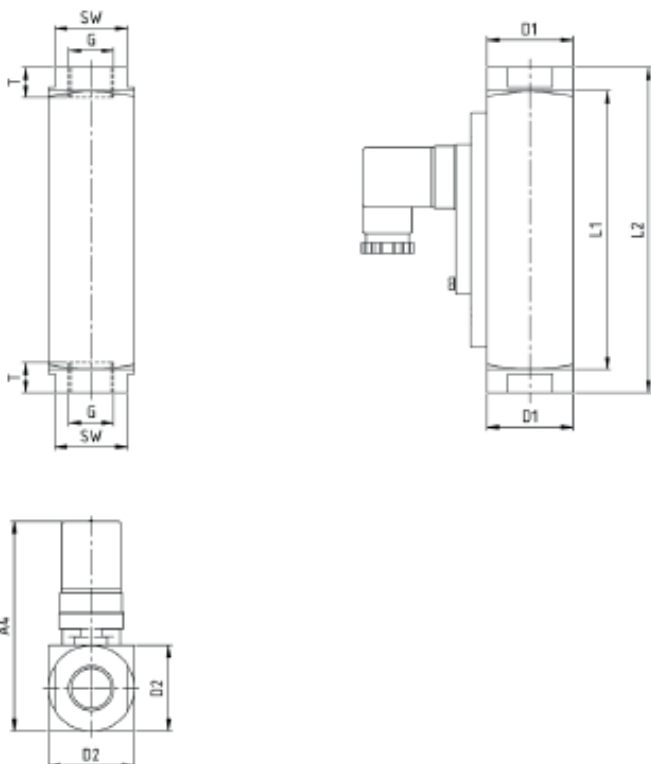

Summary of types													
Type	Overall dimensions [mm]												Weight approx. [g]
	G	DN	SW	L1	L2	T	D1	D2	A1	A2	A3	A4	
DKME-1/20	1/2"	15	34	130	152	14	40	40					1425
DKME-1/40	3/4"	20	34	130	152	15	40	40	-	-	-	~98	1340
	1"	25	40	130	130	17	40	40	-	-	-	~98	1160
DKME-1/50	3/4"	20	34	130	152	15	40	40					1340
DKME-1/60	1"	25	40	130	130	17	40	40	-	-	-	~98	1160
DKME-1/70	1"	25	40	130	130	17	40	40	-	-	-	~98	1160
DKME-1/80													

D-EN-DKME-20200526



Flow Monitors DKME-1, viscosity compensated Float measuring principle for liquids

Connection diagram

Connector in compliance with EN 175301-803
and cable

M12x1

Change over (COC)

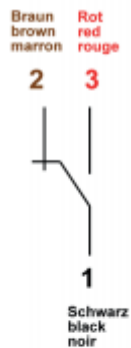

Change over (COC)



Normally open (NOC)



Normally open (NOC)



Pin-assignment

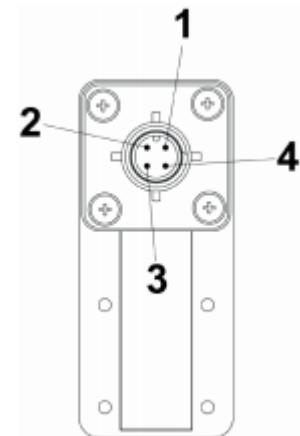



Flow Monitors DKME-1, viscosity compensated Float measuring principle for liquids

Electrical data	
Change over (COC)	250 V • 1,5A • 50 VA (3)
Normally open (NOC)	250 V • 3A • 100 VA
Change over M12x1 (-20°C – 85°C)	250 V • 1,5 A • 50 VA (3)
Normally open M12x1 (-20°C – 85°C)	250 V • 3 A • 100 VA
Change over PLC	250 V • 1 A • 60 VA
EX-version in compliance with ATEX directive	
ATEX II 2G Ex mb II T6 & ATEX II 2 D Ex tD A21 IP67 T80 °C	
ATEX II 2G Ex mb II T5 & ATEX II 2 D Ex tD A21 IP67 T100 °C	
Change over	250 V • 1A • 30 VA (3)
Normally open	250 V • 2A • 60 VA
UL recognized switch contacts	
Change over	250 V • 1,5 A • 50 VA (3)
Normally open	250 V • 3 A • 100 VA

(3) Minimum load 3 VA



Flow Monitors DKME-1, viscosity compensated Float measuring principle for liquids

Electrical connection

- Connector in compliance with EN 175301-803, Form A (DIN 43650, Form A)
- Connector M12x1
- Cable (1 m)

EX-version in compliance with ATEX directive

- Cable (2 m)

UL Recognized switch contacts

- Connector in compliance with EN 175301-803, Form A
- Cable (1 m)

Ingress Protection

IP65: Connector in compliance with EN 175301-803, Form A

IP67: Cable or connector M12x1

Output signal

The contact opens / changes when the flow decreases below the set point.

Power supply

Not required (potential-free reed contacts)

Connector types

Other connector types or cable lengths on request

Important instructions!

Technical changes and errors reserved.

Pictures can be similar.

The operating instructions belonging to this device must be observed! Download at www.schmidt-messtechnik.com.