



Short-tube flow meter SGK 1 - 3

Flow meter / flow monitor according to the float principle for monitoring liquids and gases



- Direct-reading scale
- Simple and reliable
- Short tube design
- For process flow measurement of gases and liquids
- Measurement of small and very small quantities



Short-tube flow meter SGK 1 - 3

Flow meter / flow monitor according to the float principle for monitoring liquids and gases

Features

- Direct-reading scale
- Simple and reliable
- Short-tube design
- For process flow measurement of gases and liquids
- For measurement of small and minimum volumes
- Calibrated scale specific to the process fluid
- Optionally
 - Proportioning valve
 - Floating reed switch
 - Inductive switch
 - Explosion-proof design

Applications

The devices are suitable for use on small furnace plants, in dosing systems and for monitoring small volumes in cooling processes.

Function

The SGK 1 - 3 flow meters are based on the variable area float principle. They consist of a combination of borosilicate glass measuring cone and float, with a flow scale specific to the process fluid and calibrated to customer requirements. The SGKs can optionally be equipped with a valve and can then be used for dosing small and minimum volumes of clear gases and liquids.

Installation information

- The operating instructions for SGK 1 - 3 must be observed!
- Download under www.schmidt-messtechnik.de

Type series	
SGK-1	Measures smallest air- and water volumes
SGK-2	Measures medium small air- and water volumes
SGK-3	Measures small air- and water volumes
...-MSK1	With limit value switch (Normally closed)
...-MSK12	With limit value switch (Normally open)
...-MSKW	With limit value switch (Change over)
...-RC	With inductive limit value switch*
*for volume flow less than 2 l/h H ₂ O resp. 80 l/h air i.N.)	



Short-tube flow meter SGK 1 - 3

Flow meter / flow monitor according to the float principle for monitoring liquids and gases

Technical data

Device body	
Connection	external-/internal thread to DIN EN ISO 228 T1, optionally tube grommet
Designs	A - Do, see table "Designs"
Thermal endurance	80 °C with NBR gaskets 100 °C with FKM gaskets
Operating pressure	max. 10 bar, no pressure surges

Tempered measure glass	
Scale	Burnt-in scale
Length of scale SGK 1-2 Length of scale SGK 3	approx. 150 mm approx. 220 mm
Accuracy class Error limit (G) Linear limit (qG)	VDE/VDI 3513 page 2 (08/2008) 1,6 % 50 %
Calibration	According to customer requirements

Materials	
Brocket	Aluminium, black anodized
Connections	Standard: Aluminium anodized or PVC optional: 1.4571, PVDF
Gaskets	Standard: NBR (for aluminium devices); FKM (for 1.4571 devices) optional: EPDM, Perlast® (FFKM)
Measuring glass	Borosilicate glass
Float	Aluminium anodized, PVC, 1.4571, optionally PP
Valve	1.4571



Short-tube flow meter SGK 1 - 3

Flow meter / flow monitor according to the float principle for monitoring liquids and gases

Dimensions									
	G [inch]	Shape	H [mm]	h [mm]	M	L [mm]	B [mm]	D [mm]	C [mm]
SGK-1	¼	A ₁ , A ₂ , A ₀	238	213	-	ca. 22,5	27,5	30	80 (nur A ₁ , A ₂)
SGK-2	¼	A ₁ , A ₂ , A ₀	238	213	-	ca. 22,5	27,5	30	80 (nur A ₁ , A ₂)
	¼ i	B ₀ , C ₀	242	211	M5	ca. 22,5	27,5	30	80 (nur B, C)
SGK-3	½	A ₁ , A ₂ , A ₀	363	323	-	ca. 27	45	50	135 (nur A ₁ , A ₂)
	½	B ₀ , C ₀	363	320	M8	ca. 27	45	50	135 (nur B, C)
	½ i	D ₀	363	317	M8	ca. 27	45	50	-

Design

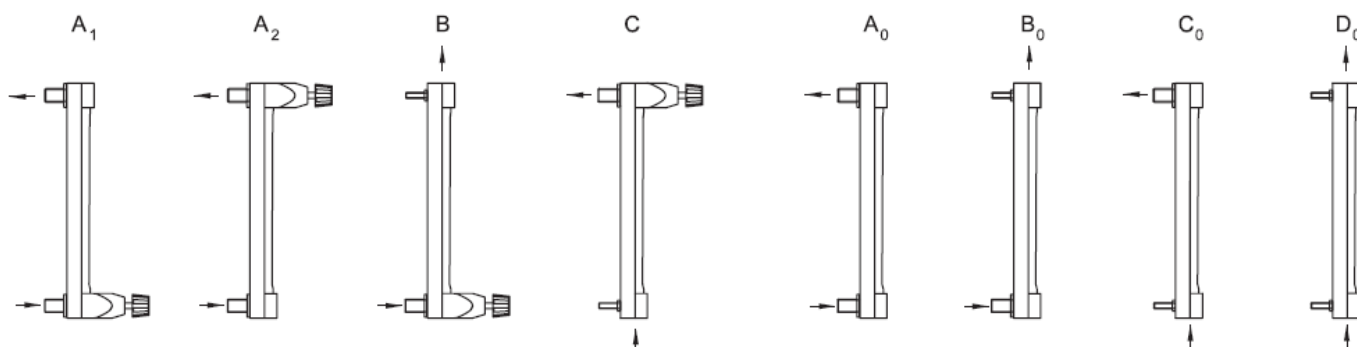

Measuring range		
	Air at STP ¹	H ₂ O
SGK-1	0,3 – 3 l/h	0,1 – 1 l/h
	0,25 – 2,5 m ³ /h	15 – 150 l/h
SGK-2	6 - 60l/h	0,5 – 5 l/h
	0,58 – 5,8 m ³ /h	20 – 200 l/h
SGK-3	0,15 – 1,5 m ³ /h	12 – 120 l/h
	1,6 – 16 m ³ /h	0,12 – 1,2 m ³ /h

D-EN-SGK-20211025



Short-tube flow meter SGK 1 - 3

Flow meter / flow monitor according to the float principle for monitoring liquids and gases

Design

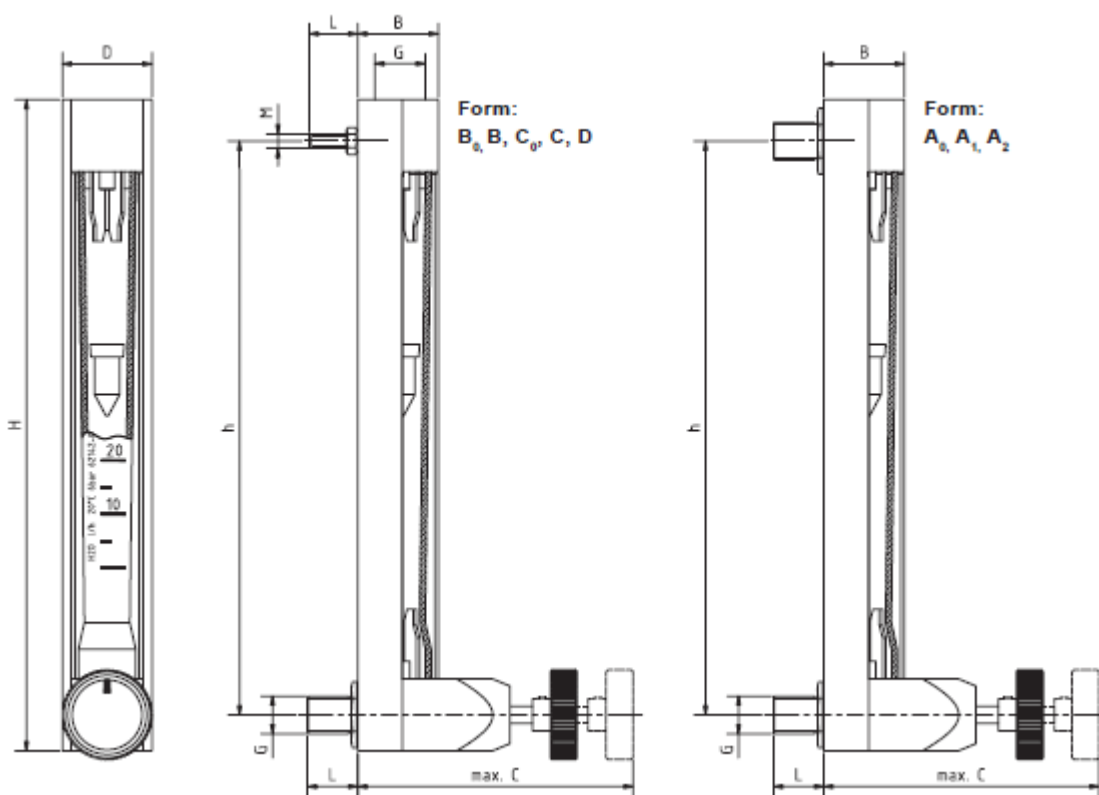



Short-tube flow meter SGK 1 - 3

Flow meter / flow monitor according to the float principle for monitoring liquids and gases

Limit value switches RC

Up to a flow rate of 2 l/h H₂O or 80 l/h air at STP, the RC inductive switches are available for monitoring limit values. They should be operated together with isolation switching amplifier KFA6-SR2-Ex1W.

Reed switches of the MSK series are available for flow rates above these values.

Limit value switches MSK1/MSK12/MSKW

In order to realize a local display with a monitoring function the flowmeter can be equipped with limit value switches. The limit value switch consists of a connector housing and a bistable reed switch.

A magnet integrated in the float switches this reed switch. The limit value switch is guided in a guide slot on the back of the protective tube and can be adjusted throughout the entire measuring range. In case of inductive or capacitive load applications, e.g. caused by contactors or solenoid valves, uncontrolled current and voltage peaks may occur. In dependence on their geometry such peaks also occur in lines if they exceed a certain length. It is therefore recommended to use an additionally available arc suppression relay "MSR". This increases the switching capacity and avoids the appearance of inductive and capacitive peaks. It thereby ensures a long lifetime of the contact.



Short-tube flow meter SGK 1 - 3

Flow meter / flow monitor according to the float principle for monitoring liquids and gases

Technical data of the limit value switches

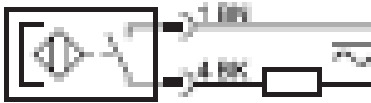
Design	MSK1	MSK12
Switching voltage	50 V AC/75 V SC	50 V AC/75 V SC
Switching current	max. 0,5 A	max. 0,5 A
Switching capacity	max. 10 W/VA	max. 10 W/VA
Dielectric strength	230 V AC/400 V DC	230 V AC/400 V DC
Temperature range ¹	-20...+90 °C	-20...+90 °C
Switching function	Normally closed	Normally open
Connection		
¹ The thermal endurance of the flow meter is crucial.		

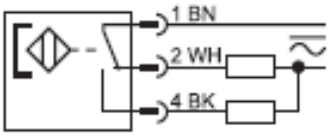
Design	MSKW
Switching voltage	50 V AC/75 V SC
Switching current	max. 0,5 A
Switching capacity	max. 5 W/VA
Dielectric strength	110 V AC/200 V DC
Temperature range ¹	-20...+90 °C
Switching function	Change over
Connection	
¹ The thermal endurance of the flow meter is crucial.	



Short-tube flow meter SGK 1 - 3

Flow meter / flow monitor according to the float principle for monitoring liquids and gases

Design	RC 10-14-N3	RC 15-14-N3
Inner diameter	10 mm	15 mm
Rated voltage	8 V DC	
Current consumption	1 mA/3 mA	
Sweep rate	≤ 10 m/s	
Self-inductance	≤ 120 mH	
Self-capacitance	≤ 90 nF	
Temperature range	-20...+70 °C	
Switching function	NAMUR bistabile	
Connection		

Low Voltage Directive

Above 50 V AC/75 V DC, electrical components are subjected to the EU Low Voltage Directive (LVD). The user is required to verify their use accordingly.

Proper use

The user is responsible for assessing the suitability of the flow meters for his case of application, for use as prescribed and for material compatibility regarding the liquid product used in his process. The manufacturer shall not be liable for any damage arising from incorrect or improper use of the devices. Pressure surges can cause glass breakage and should therefore generally be avoided. The limit values given in the data sheet should be observed. In all other respects we advise following the installation recommendations specified in Code VDI/VDE 3513, Sheet 3.

Important instructions!

Technical changes and errors reserved.
Pictures can be similar.

The operating instructions belonging to this device must be observed! Download at www.schmidt-messtechnik.com.