



Flow Monitor PAM-POM

Flow monitor made of PVC, according to the baffle plate principle for monitoring liquids, adhesive tube connection



D-EN-POM-PVC_20190311

- Plastic version (POM) – no corrosion
- Easy adjustment of the switching point by means of set screw
- No spring – always the same resetting force
- Low pressure loss
- Very inexpensive



Flow Monitor PAM-POM

Flow monitor made of PVC, according to the baffle plate principle for monitoring liquids, adhesive tube connection

Function

The flow monitor PAM-POC works according to the pendulum principle with magnetic resetting.

The paddle protruding into the flow is absorbed by a bearing. On the opposite side a magnet is attached. A second external magnet repels the paddle magnet. This creates a restoring force.

This force is adjustable by changing the propriety of the magnets by means of a screw, so that the switching point of the device can be adjusted easily and accurately. The magnet, which is located on the pendulum, operates without contact with an externally mounted reed switch.

Features

- Plastic version (POM) – no corrosion
- Easy adjustment of the switching point by means of set screw
- No spring – always the same resetting force
- Low pressure loss
- Different versions, easy adaptation to different requirements
- Very inexpensive

Application

The PAM-POM offers a very inexpensive and yet flexible option for monitoring flow rates. PAM-POM is made completely of plastic.

Technical data

Switching capacity	180 V, 10 W, 0,5 A max. (other versions available on request)
Switch	Normally open contact (closes contact and change over contact on request)
Temperature max.	100 °C
Pressure max.	PN10

Technical drawing

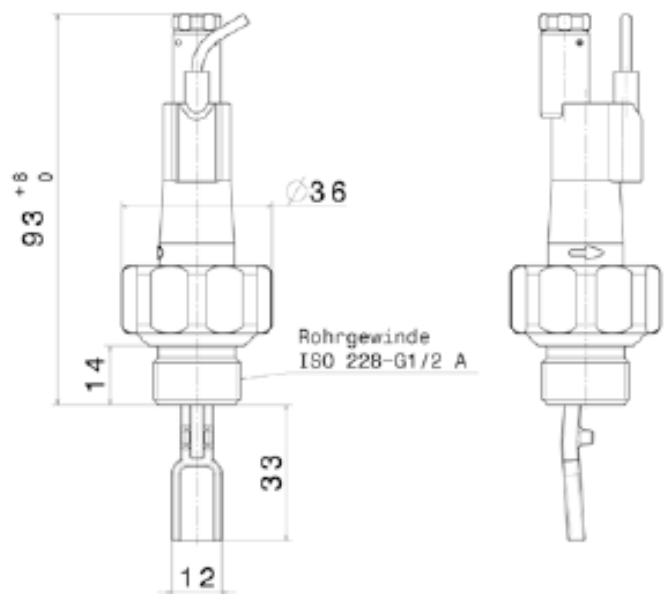



Flow Monitor PAM-POM

Flow monitor made of PVC, according to the baffle plate principle for monitoring liquids, adhesive tube connection

Flow rate			Dimensions		
DN	Rp	Flow rate l/min*	A mm	B mm	C mm
DN32	1 1/4"	10-25	See drawing		
DN40	1 1/2"	15-38			
DN50	2"	20-50			
DN65	2 1/2"	34-85			
DN80	3"	50-125			
DN100	4"	80-200			
DN125	5"	150-400			
DN150	6"	250-600			

*Other ranges / switching points on request

Materials	
Housing	Noryl GFN3
Screw-in part/T-piece	POM
Pendulum	Noryl GFN3
Temperature max.*	100°C
Pressure max.	PN 10

* Medium temperature