



# Operating Manual

## Multifunctional Electronics MFE

Battery powered	MFE-1
Battery powered, pulse output	MFE-2
Power supply, pulse output, current output	MFE-3



- For oval gear meters of the series OR, OR Plus, OF
- Ex ib IIC T4 in accordance with IEC-Ex  
 II 2G Ex ib IIC T4 in accordance with ATEX

B-EN-MFE-20200203



## Operating Manual Multifunctional Electronics MFE

### Content

1.	Preface	4
1. I.	Transport, delivery, storage	4
1. II.	Warranty	4
1. III.	Safety information	4
2.	Area of application	4
3.	Characteristic values	5
3.1.	Electrical and thermal safety relevant data	5
4.	Operating conditions	6
4.1.	Installation conditions	6
4.1.1.	General installation instructions	6
4.1.2.	Installation	6
4.2.	Ambient conditions	6
4.2.1.	Ambient temperature	6
4.2.2.	Storage temperature	6
4.2.3.	Degree of protection	6
4.2.4.	Electromagnetic compatibility	6
5.	Constructive design	6
5.1.	Power supply	7
5.2.	Sensor connection (only MFE-2 and MFE-3)	7
6.	Display and user interface	7
6.1.	Display	7
6.2.	Key functions in normal mode	8
6.3.	Operating manu	8
6.3.1.	Key functions	8
6.3.2.	Operating modes (level 1)	10
6.3.2.1.	Return identification	10
6.3.2.2.	Total volume measurement	10
6.3.2.3.	Difference measurement	10



# Operating Manual

## Multifunctional Electronics MFE

6.3.3.	Volume units (level 2)	10
6.3.4.	Time units (level 3)	11
6.3.5.	Digits after the decimal point for flow or volume (level 4 and 5)	11
6.3.6.	K factors (level 6 and 12)	11
6.3.7.	Density calculation (level 13)	11
6.3.8.	Medium temperature level 14) (only MFE-3)	11
6.3.9.	Pulse outputs (level 24 and 25) (only MFE-2 and MFE-3)	12
6.3.9.1.	Original pulses	12
6.3.9.2.	Scaled pulses (only MFE-2 and MFE-3)	12
6.3.10.	Gate time flow display (level 34)	12
6.3.11.	Attenuation factor (level 35)	13
6.3.12.	Total volume meter reset (level 36)	13
6.3.13	Current output (level 123 and 124)	13
6.3.14	Current simulation (level 125) (only MFE-3)	14
6.3.15	Password (level 146) (only MFE-3)	14
6.4.	Open collector pulse output	14
6.5.	Connection examples	15
6.5.1.	Connection MFE-2	15
6.5.1.1.	Non hazardous area (only MFE-2)	15
6.5.1.2.	Hazardous area (only MFE-2)	15
6.5.2.	Connection MFE-3	16
6.5.2.1.	Non hazardous area (only MFE-3)	16
6.5.2.2.	Hazardous area (only MFE-3)	16
6.6.	Operating menu	17
7.	Certificates and approvals	19
Appendix		19
A	Trouble shooting	19
B	Battery service life and replacing the battery	20
C	Certificates	21
Important notes		22



## Operating Manual Multifunctional Electronics MFE

### I. Transport, Delivery, Storage

#### Storage and transport

Always protect the devices against humidity, soiling, impacts and damages.

#### Delivery inspection

Report any in-transit damage immediately upon delivery. Any damage reported at a later date will not be recognized.

### II. Warranty

Please refer to the contractual terms and conditions relating to delivery for the scope and period of warranty. Warranty claims shall be conditional to correct installation and commissioning in accordance with the operating instructions of the device. The necessary installation, start-up and maintenance work should only be carried out by qualified and authorized personnel.

### III. Safety Information

1. The devices have to be installed, operated and serviced by qualified personnel. The operator has to ensure that personnel have received sufficient and appropriate training. In case of doubt, please contact the manufacturer.
2. Symbols in this document



#### **Warning!**

Indicates a situation that, if not avoided, may result in injury or a safety risk.



#### **Caution!**

Indicates a situation that, if not avoided, may result in malfunctioning or destruction of the device.

### 2. Area of Application

The MFE multifunctional electronics reevaluates the original pulses of an oval wheel meter in a quantity or flow display. The values are shown on an LC display.

MFE-2 provides a pulse output for evaluation.

MFE 3 provides a current output 4...20 mA and a pulse output for evaluation.



# Operating Manual

## Multifunctional Electronics MFE

### 3. Characteristic Values

#### 3.1 Electrical and thermal safety relevant data

Transducer electric circuit with Ex ib IIC protection for connecting a passive sensor (reed sensor).

##### MFE-1 and MFE-2:

Voltage	$U_0$	=	3.6 V
Current	$I_0$	=	< 1mA
Power	$P_0$	=	< 1mW
Max. outer capacity	$C_0$	=	1 $\mu$ F
Max. outer inductivity	$L_0$	=	1 mH

##### MFE-3:

Voltage	$U_0$	=	5.9 V
Current	$I_0$	=	7 mA
Power	$P_0$	=	10 mW
Max. outer capacity	$C_0$	=	1 $\mu$ F
Max. outer inductivity	$L_0$	=	1 mH

**Output electric circuit** (open collector) in the hazardous area with Ex ib IIC protection for connection to intrinsically safe electric circuits.

##### MFE-2 and MFE-3:

Voltage	$U_1$	=	30 V
Current	$I_1$	=	100 mA
Power	$P_1$	=	0.5 W
Max. outer capacity	$C_1$	=	-
Max. outer inductivity	$L_1$	=	50 $\mu$ H

An ambient temperature range of  $-20^{\circ}\text{C} \leq T_a \leq +70^{\circ}\text{C}$  applies for the MFE.  
The influence of the process temperature on the electronics must be considered.



## Operating Manual Multifunctional Electronics MFE

### 4. Operating Conditions

#### 4.1 Installation conditions

##### 4.1.1 General installation instructions

- Hazardous area: The installation of the electronics must ensure that electrostatic charging is impossible.

##### 4.1.2 Installation

- The cable gland must face downwards or to the side. (see illustration on the right)
- The MFE-2 and MFE-3 electronics can either be mounted on a meter or separately. Always observe the ambient and storage temperatures!
- MFE-1 can be only mounted directly onto a meter.
- The display can be rotated in 90° steps.

#### 4.2 Ambient conditions

##### 4.2.1. Ambient temperature

-20°C to +70°C

##### 4.2.2 Storage temperature

+10°C to + 55°C

##### 4.2.3 Degree of protection

IP 65 (for correct installation on the measurement chamber or wall mounting unit)

##### 4.2.4 Electromagnetic compatibility

Electromagnetic compatibility is guaranteed.

DIN EN 61000-6-2 interference immunity for industrial areas

DIN EN 61000-6-3 interference immunity for residential areas

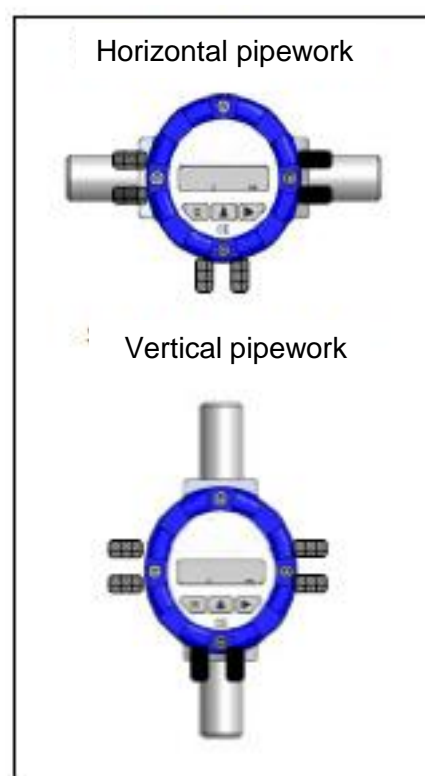

### 5. Constructive Design



#### Warning!

For reasons of explosion protection and guarantee no electronic components may be exchanged for electronic components of other counters.



## Operating Manual Multifunctional Electronics MFE

### 5.1 Power supply

**MFE-1 and MFE-2:** The power supply occurs via a 3.6 V lithium battery integrated in the UP-GF polyester housing.

Hazardous area:

Only use batteries from the manufacturer in the hazardous area. (Please state "hazardous area" on repeat orders.)

**MFE-3:** Power supply: 10 - 30 VDC with 4-20mA current output.

Ensure there is an uninterruptible power supply, as meter values are saved in the memory element every two hours. Risk of data loss during this time period!

Hazardous area: The power supply in a hazardous area occurs via a transmitter supply unit; see 6.5 Connection examples.

### 5.2 Sensor connection

(only MFE-2 and MFE-3)

The MFE-2 and MFE-3 contain two cable bushings for one external sensor and/or pulse output. The terminal compartment has up to two reed sensors that can be connected via plug-in connectors. The electronics can be combined with any meter that uses reed sensors.

**External sensor:**

The external reed sensor can transmit pulses to either pulse input A or B depending on the measuring task and the operating mode. A sliding switch  $A \leftrightarrow B$  is provided on the connection circuit board for this purpose. An external sensor with a cable length of up to 30m can always be connected at terminals 1 and 2. Additionally, an internal reed sensor can be used to transmit pulses to the other pulse input. It is therefore possible to carry out consumption measurements.

## 6. Display and User Interface

### 6.1 Display

The display is an 8-digit 7-segment numeric display containing 20 information elements.

The information elements are used to display the unit, operating statuses, sensor signals, programming symbols, etc.

Use the "▲" key to select the display: Q → V1 → V2 → Q → V1 → V2 ....





## Operating Manual Multifunctional Electronics MFE



### Explanation of the display symbols:

- "A" or "B" is displayed for approx. 0.5 s when a pulse is generated at the sensor.
- "Prog" indicates that the device is in programming mode.
- "Q" and the respective flow unit are displayed together with the flow rate.
- Volumes are displayed via "V1" total volume meter or "V2" daily volume meter. The volume units are shown accordingly. The "V2" meter can always be reset via the "R" key. The "V1" meter can only be reset via the programming menu after entering the correct password. The password prompt is deactivated upon delivery.
- The menu steps and the volume meters V1 or V2 are displayed in the programming mode and the normal mode respectively via the numbers 1/2/3/4/5/6.

The daily volume meter and total volume meter do not display values below zero.

### 6.2 Key functions in normal mode

Press the "▲" key to go to the next displayed mode.

If the daily volume is displayed, it can be reset to zero by pressing the "R" key.

The total volume meter "Volume 1" can only be reset in programming mode after entering a password (see table under section 6.6).

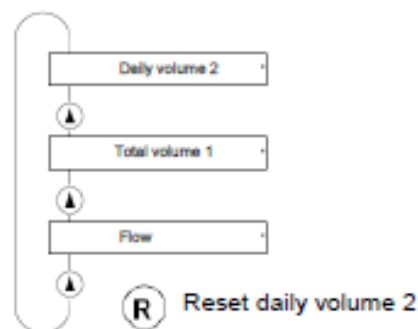

### 6.3 Operating menu

#### 6.3.1 Key functions

Press the "▶" key for approx. 2 s to go to the programming mode ("1" and "Prog" appear on the left and at the top of the display respectively). Press the "R" key to navigate through the individual levels. The normal mode is reached automatically after level 146 software version.

After reaching the level which needs to be altered, press the "▶" key once. "Prog" flashes and the value can be altered as described in the examples.





## Operating Manual Multifunctional Electronics MFE

Examples:

Level 2 flow or volume unit:

For example, the unit "gal" is displayed. Press the "▲" key to change the unit setting to "g" (continue to press the key to set the units "kg", "t", "l" or "m³"). Once the desired unit has been set, press the "▶" key to save it.

Level 6 K factor:

The K factor is displayed as 0880.0000. This needs to be changed to 0200.000. The first digit can be altered when "Prog" flashes. Press the "▶" key to move to the second digit. Press the "▲" key to increase the value by "1". Press the key until "2" has been set and use the "▶" key to move to the next digit. Continue this process until all the values have been set as desired.

### 6.3.2 Operating modes (level 1)

#### 6.3.2.1 Return identification

Return identification is possible when using two sensors at one measuring chamber. The flow is displayed as a negative value during the return process. At the same time, both volume meters are decremented. Return identification is only possible when pulses A and B overlap. The maximum input frequency that can be processed is 200 Hz. Negative values are not displayed after the V1 or V2 meter has returned to "0". The quantity is lost! "E" appears on the display during the return process. The message "E" is saved and can be deleted by pressing the "▶" key. Select operating mode "1".

#### 6.3.2.2 Total volume measurement

"A" + "B" is calculated as the total volume measurement for the volume / mass measurement. There is no return identification. Separate K factors are applied.

The total of "A+B" is displayed at all meters. K factor A and B can be set separately. Select operating mode "2".

#### 6.3.2.3 Difference measurement

"A-B" is calculated as the difference measurement for the volume / mass measurement. There is no return identification. Separate K factors are applied.

The electronics can record pulses from two different measuring chambers. The forward quantity is, e.g., measured by the internal reed sensor "A". The external reed sensor then measures the pulses of the separately mounted return quantity meter via the external reed sensor "B" (terminal positions 1+2). A K factor must be programmed for each sensor. The difference "A-B" is displayed at all the meters. A number below zero is impossible; the smallest value that can be displayed at the volume meter is "0". Select operating mode "3".

### 6.3.3 Volume units (level 2)

The displayed volume unit can be freely selected (litre, cubic metre, gallons, grams, kilograms, tonnes).

There is no automatic conversion of the previously accumulated volume in the new unit when changing the selected volume unit in level 2 or when changing the number of digits after the decimal point for V in level 5. All the current meter readings are deleted (reset) when changing the volume unit. It is recommended to activate password protection to prevent accidental deletion. Always observe possible effects on the current output.

#### Mass display

To display the mass, a fixed density in kg/m³ and an alpha value in kg/m³/°C must be entered in the programming menu. The density and the alpha value are used to convert volumes to mass. When selecting a mass volume unit (g, kg or t), the calculated or fixed density is accessed automatically depending on whether a temperature sensor is connected or not.



## Operating Manual Multifunctional Electronics MFE

Examples:

Level 2 flow or volume unit:

For example, the unit "gal" is displayed. Press the "▲" key to change the unit setting to "g" (continue to press the key to set the units "kg", "t", "l" or "m<sup>3</sup>"). Once the desired unit has been set, press the "▶" key to save it.

Level 6 K factor:

The K factor is displayed as 0880.0000. This needs to be changed to 0200.000. The first digit can be altered when "Prog" flashes. Press the "▶" key to move to the second digit. Press the "▲" key to increase the value by "1". Press the key until "2" has been set and use the "▶" key to move to the next digit. Continue this process until all the values have been set as desired.

### 6.3.2 Operating modes (level 1)

#### 6.3.2.1 Return identification

Return identification is possible when using two sensors at one measuring chamber. The flow is displayed as a negative value during the return process. At the same time, both volume meters are decremented. Return identification is only possible when pulses A and B overlap. The maximum input frequency that can be processed is 200 Hz. Negative values are not displayed after the V1 or V2 meter has returned to "0". The quantity is lost! "E" appears on the display during the return process. The message "E" is saved and can be deleted by pressing the "▶" key. Select operating mode "1".

#### 6.3.2.2 Total volume measurement

"A" + "B" is calculated as the total volume measurement for the volume / mass measurement. There is no return identification. Separate K factors are applied.

The total of "A+B" is displayed at all meters. K factor A and B can be set separately. Select operating mode "2".

#### 6.3.2.3 Difference measurement

"A-B" is calculated as the difference measurement for the volume / mass measurement. There is no return identification. Separate K factors are applied.

The electronics can record pulses from two different measuring chambers. The forward quantity is, e.g., measured by the internal reed sensor "A". The external reed sensor then measures the pulses of the separately mounted return quantity meter via the external reed sensor "B" (terminal positions 1+2). A K factor must be programmed for each sensor. The difference "A-B" is displayed at all the meters. A number below zero is impossible; the smallest value that can be displayed at the volume meter is "0". Select operating mode "3".

### 6.3.3 Volume units (level 2)

The displayed volume unit can be freely selected (litre, cubic metre, gallons, grams, kilograms, tonnes).

There is no automatic conversion of the previously accumulated volume in the new unit when changing the selected volume unit in level 2 or when changing the number of digits after the decimal point for V in level 5. All the current meter readings are deleted (reset) when changing the volume unit. It is recommended to activate password protection to prevent accidental deletion. Always observe possible effects on the current output.

#### Mass display

To display the mass, a fixed density in kg/m<sup>3</sup> and an alpha value in kg/m<sup>3</sup>/°C must be entered in the programming menu. The density and the alpha value are used to convert volumes to mass. When selecting a mass volume unit (g, kg or t), the calculated or fixed density is accessed automatically depending on whether a temperature sensor is connected or not.



## Operating Manual Multifunctional Electronics MFE

### 6.3.4 Time units (level 3)

The time unit for the flow display (h/ min/ s) can be freely selected.

### 6.3.5 Digits after the decimal point for flow or volume (level 4 and 5)

The number of digits after the decimal point can be set separately for the flow and volume display.

Select up to 3 digits after the decimal point.

Always observe possible effects on the current output when making changes!

### 6.3.6 K factors (level 6 and 12)

The volume or flow is calculated by multiplying the generated pulses with the device-specific K factor.

A K factor must be programmed for each meter in the difference measurement and the total volume measurement mode.

Only MFE-3: After changing the K factor the meter V1 has to be reset in the programming menu (see section 6.3.12).

### 6.3.7 Density calculation (level 13)

#### Example 1: No temperature sensor connected

The expected process density is entered in level 13. This fixed density is used to continuously calculate the mass volume.

#### Example 2: PT1000 connected (only for MFE-3)

Enter the density of the medium at 20°C in level 13. Enter the alpha value, i.e. the change of medium density, in kg/m<sup>3</sup>/°C in level 23. The alpha value is always positive! The temperature of the connected PT1000 is recorded and displayed in level 14. The temperature is recorded in 0.5° steps. (Please observe the permissible temperature for meters and the electronics!) The electronics uses the density, alpha value and the recorded temperature to calculate the operating density of the medium. This variable operating density is used to calculate the mass volume.

#### Example:

Temperature:	27°C	(can be read in level 14)
Density at 20°C:	998.2 kg/m <sup>3</sup>	(must be entered in level 13)
Alpha values:	0.2 kg/m <sup>3</sup> /°C	(must be entered in level 23)

#### Calculation:

$27^{\circ}\text{C} - 20^{\circ}\text{C} = 7^{\circ}\text{C}$  (temperature difference to 20°C)

$7^{\circ}\text{C} * 0.2 \text{ kg/m}^3/^{\circ}\text{C} = 1.4 \text{ kg/m}^3$  (change of density compared to 20°)

$998.2 \text{ kg/m}^3 - 1.4 \text{ kg/m}^3 = 996.8 \text{ kg/m}^3$  (new operating density for calculation with the current measured volume)

### 6.3.8 Medium temperature (level 14) (only MFE-3)

The MFE-3 multifunctional electronics provides a connection for a PT1000 sensor (optional). The current measured temperature is displayed in 0.5° steps in level 14. The medium temperature can be used to calculate the density. If a temperature sensor is not used, a temperature of 20°C is always displayed.





## Operating Manual Multifunctional Electronics MFE

### 6.3.9 Pulse outputs (level 24 and 25) (only MFE-2 and MFE-3)

#### 6.3.9.1 Original pulses

Irrespective of the operating mode, only the pulses which reach pulse input "A" are output as original pulses. The pulse duration for original pulses is always 4 ms and cannot be altered.

#### 6.3.9.2 Scaled pulses (only MFE-2 and MFE-3)

Depending on the volume/quantity of mass, pulses can be output at the pulse output. A pulse is always followed by a pulse-pause of identical duration. (Ratio 1:1)

The following pulse durations can be selected in level 25:

Pulse duration [ms]	4	12	24	48	100
Max. output frequency [Hz]	125	42	21	10	5

Select the type of pulse output in level 24:

0: Original pulses

1-8: Scaled pulses

OFF: No pulse output

0	1	2	3	4	5	6	OFF
---	---	---	---	---	---	---	-----

Pulses are not lost. If the max. output frequency is briefly exceeded due to an excessive flow rate, the pulses are metered in a "pulse buffer". This buffer outputs the remaining pulses once the flow rate has been reduced.

The display (V1) is used to determine the scaling.

Display V1: 1357,246

Definition of the positions for the following explanations:

Position 1 = far right, Position 2 = second from right, etc.

Position: 6 5 4 3 2 1

#### Example 1:

Setting "1" has been selected in level 24 (= position 1):

Meter reading (V1): 01357.246 kg

If position 1 changes from 8 to 7, the pulse buffer increases by 1.

→ The pulse buffer increases by 1 every time position 1 changes.

The pulses are output immediately.

#### Example 2:

Setting "4" has been selected in level 24 (= position 4):

Meter reading (V1): 01357.246 m<sup>3</sup>

If position 4 changes from 7 to 8, the pulse buffer increases by 1.

→ The pulse buffer increases by 1 every time position 4 changes.

#### Example 3:

Setting "4" has been selected in level 24 (= position 4):

The pulse buffer increases by 10 pulses if position 5 changes from 5 to 6, since this represents a 10 step change to position 4. The pulses are output immediately.

Clever selection of the scaling factor (level 24) and the pulse duration (level 25) can help to achieve a high resolution without reaching the maximum output frequency of the meter.

Caution: Subsequent changes to the number of digits after the decimal point for the volume can affect the output of the scaled pulses! The setting in level 24 must then be corrected.

### 6.3.10 Gate time flow display (level 34)

The set time rate corresponds to the update rate of the display.

For example: With a set gate time of 1.5 seconds, the display shows a current measured value every 1.5 seconds.



## Operating Manual Multifunctional Electronics MFE

### 6.3.11 Attenuation factor (level 35)

The attenuation factor determines the number of measured values required to create the variable mean value.

For example: A set attenuation value of 2 uses the last 2 displayed values to calculate a variable mean value.

### 6.3.12 Total volume meter reset (level 36)

If "V2" is displayed, the meter (V2) can be reset by pressing the "R" key. The meter (V1) can only be reset via the programming menu.

Password function:

**MFE-1 and MFE-2:** The password (4-digit number) is only required to reset the main meter. The password is preset during production and cannot be changed by the customer. The device comes with a printed protocol ("Device Configuration MFE Electronics") containing all the programmed parameters. The password is specified under point "146 reset code total volume meter".

**MFE3:** The password is required to access the programming level. The password can be set by the customer at level 146. If the password is "0000", the password prompt is deactivated for programming level access. The device comes with a printed protocol ("Device Configuration MFE Electronics") containing all the programmed parameters. The password is specified under point "146 password". The password is preset to "0000" upon delivery.

Resetting the main meter:

**MFE-1 and MFE-2:** At level 36, the correct password must be entered to reset the total volume meter. (Password – see protocol "Device Configuration MFE")

**MFE-3:** After accessing the programming level, change "0" to "1" in channel 36 in order to reset the main meter.

The meter (V1) is reset to 0 after exiting the programming menu.

### 6.3.13 Current output (level 123 and 124) (only MFE-3)

The measured flow rate in the "Q" display can be output as current at the 4-20 mA current output.

The flow rate value for the lower measuring range limit (4 mA) and the flow rate value for the upper measuring range limit (20 mA) are displayed in level 123 and 124 respectively. 4 mA usually corresponds to flow rate zero ("life zero").



#### Caution!

The number of digits after the decimal point for channels 123 and 124 corresponds to the number of decimal points selected in level 4.  
When changes occur in level 4, always check and correct the measuring ranges in level 123 and 124!



## Operating Manual Multifunctional Electronics MFE

### 6.3.14 Current simulation (level 125)

(only MFE-3)

Any value between 04.00 and 20.00 mA can be set. The set value is output as current. Current simulation is terminated when exiting the programming menu.



#### Caution!

Current simulation can affect the running process!

### 6.3.15 Password (level 146)

(only MFE-3)

A password required to enter the programming level can be allocated as protection against accidental or unauthorized changes to the program. A 4-digit combination can be entered as the password in level 146. The password "0000" deactivates password protection.

When password protection is activated, the programming level can only be accessed after entering the correct password. Please do not forget the set password, e.g. make a note of it.

## 6.4 Open collector pulse output



#### Caution!

In a hazardous area, the open collector output must be supplied in an intrinsically safe manner. Please observe the connection values specified under 3.1 Electrical and thermal safety relevant data.

MFE-2 and MFE-3



#### Caution!

Generally speaking, the passive open collector output must be connected via an approx. 10 k $\Omega$  pull-up resistor.

**MFE-2:** The output pulses can be picked up at terminals 4 and 5. Set the open collector at terminal 5 to a resistance of approx. 10 k $\Omega$  for voltages of between 5 and max. 24V. The current carrying capacity of the output is max. 30 mA. If a voltage is applied to terminal 5 without resistance, the output stage of the electronics will be destroyed.

**MFE-3:** The output pulses can be picked up at terminals 7 and 8. Set the open collector at terminal 8 to a resistance of approx. 10 k $\Omega$  for voltages of between 5 and max. 24V. The current carrying capacity of the output is max. 30 mA. If a voltage is applied to terminal 8 without resistance, the output stage of the electronics will be destroyed.





## Operating Manual Multifunctional Electronics MFE

### 6.5 Connection examples

#### 6.5.1 Connection MFE-2

##### 6.5.1.1 Non-hazardous area

(only MFE-2)

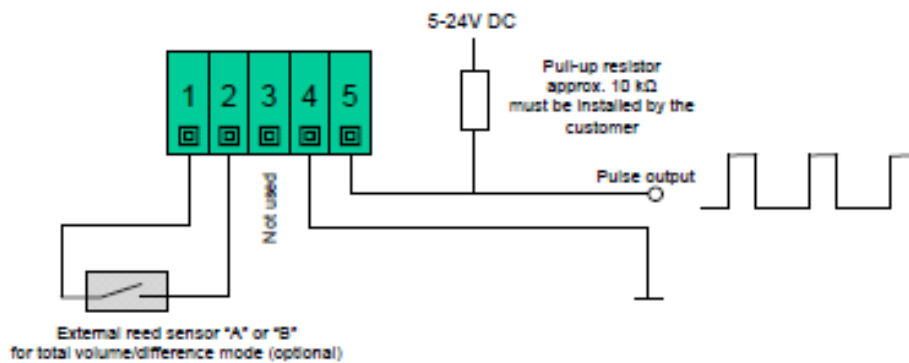

##### 6.5.1.2 Hazardous area

(only MFE-2)

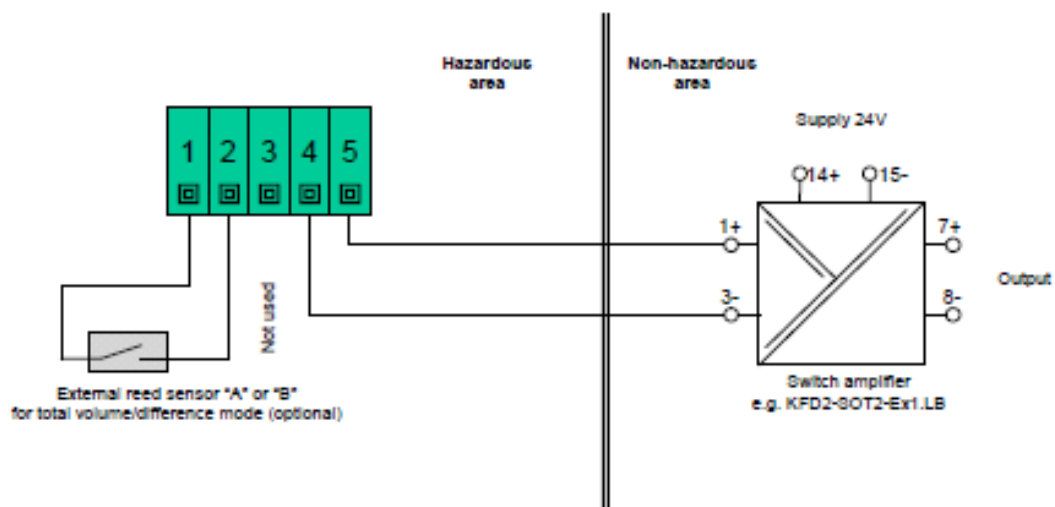

B-EN-MFE-20200203



## Operating Manual Multifunctional Electronics MFE

### 6.5.2 Connection MFE-3

#### 6.5.2.1 Non-hazardous area

(only MFE-3)

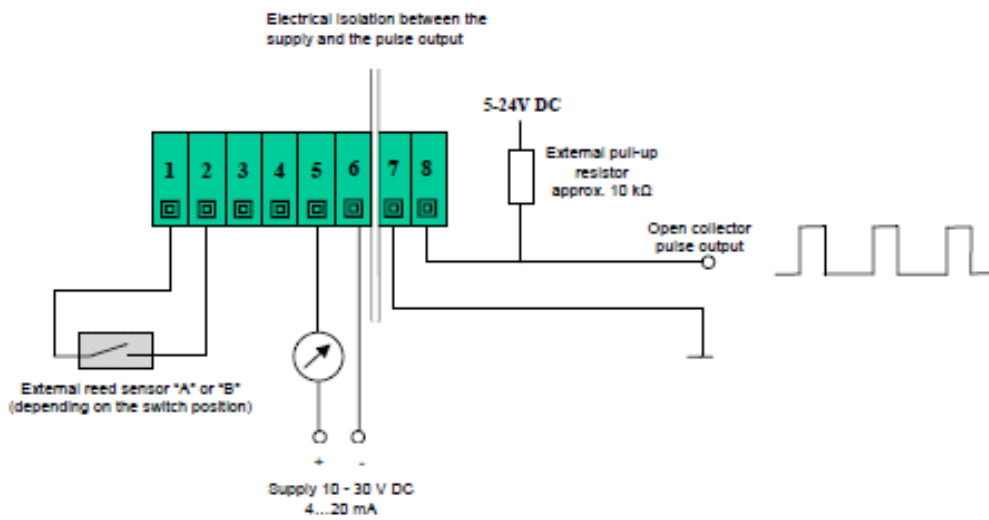

#### 6.5.2.2 Hazardous area

(only MFE-3)

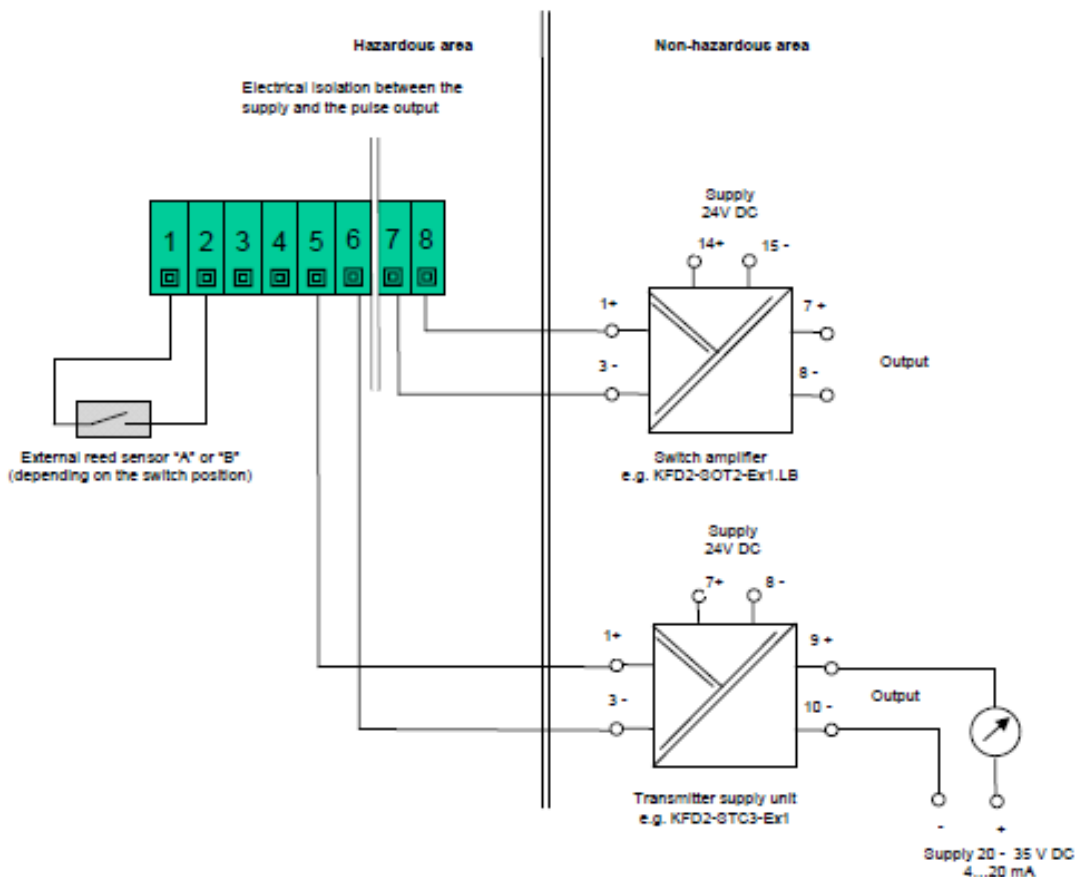

B-EN-MFE-20200203



## Operating Manual Multifunctional Electronics MFE

### 6.6 Operating menu

#### MFE-1

Level Parameters	Note
1 Operating mode	1: A and B at a measuring chamber, possibility of return identification
2 Volume unit	Selection of the volume unit. When "mass" unit, then calculation of the density
3 Time unit	Conversion of the flow rate into the selected time unit.
4 Digits after the decimal point Q	Number of digits after the decimal point for Q display: 0 to 3 digits possible
5 Digits after the decimal point V1 + V2	Number of digits after the decimal point for V1+V2 display: 0 to 3 digits possible
6 K factor A	Unit: Pulses per litre. This factor is used for sensor A.
12 Not used	
13 Density in kg/m <sup>3</sup>	Density for operating conditions
24 Not used	Default setting: "OFF"
25 Not used	
34 Gate time flow display	Period of time which the meter waits before updating the flow display.
35 Attenuation factor	Determination of the mean value via the last 1, 2, 4 or 8 mean values.
36 Total volume meter reset	Password required to reset the total volume meter
45 Max. frequency	Display of the maximum recorded frequency. (Drag indicator function)
46 Not used	
56 Software version	Display of the available software version

#### MFE-2

Level Parameters	Note
1 Operating mode	1: A and B at a measuring chamber, possibility of return identification 2: A + B (measurement of the total volume) 3: A - B (measurement of the difference = consumption measurement)
2 Volume unit	Selection of the volume unit. When "mass" unit, then calculation of the density
3 Time unit	Conversion of the flow rate into the selected time unit.
4 Digits after the decimal point Q	Number of digits after the decimal point for Q display: 0 to 3 digits possible
5 Digits after the decimal point V1 + V2	Number of digits after the decimal point for V1+V2 display: 0 to 3 digits possible
6 K factor A	Unit: Pulses per litre. This factor is used for sensor A.
12 K factor B	Unit: Pulses per litre. This factor is used for sensor B.
13 Density in kg/m <sup>3</sup>	Density for operating conditions
24 Pulse output scaling	0: Original pulses of sensor A. (pulse duration original pulses: 4ms) 1: 1 pulse per change of the right-hand position of V1 (right). 2: 1 pulse per change of the second position ....
25 Pulse duration	Pulse duration. Period duration = 2x pulse duration. [4, 12, 24, 48, 100]
34 Gate time flow display	Period of time which the meter waits before updating the flow display.
35 Attenuation factor	Determination of the mean value via the last 1, 2, 4 or 8 mean values.
36 Total volume meter reset	Password required to reset the total volume meter
45 Max. frequency	Display of the maximum recorded frequency. (Drag indicator function)
46 Not used	
56 Software version	Display of the available software version



# Operating Manual

## Multifunctional Electronics MFE

### MFE-3

Level Parameters	Note
1 Operating mode	1: A and B at a measuring chamber, possibility of return identification 2: A + B (measurement of the total volume) 3: A - B (measurement of the difference = consumption measurement)
2 Volume unit	Selection of the volume unit. When "mass" unit, then calculation of the density
3 Time unit	Conversion of the flow rate into the selected time unit.
4 Digits after the decimal point Q	Number of digits after the decimal point for Q display: 0 to 3 digits possible
5 Digits after the decimal point V1 + V2	Number of digits after the decimal point for V1+V2 display: 0 to 3 digits possible
6 K factor A	Unit: Pulses per litre. This factor is used for sensor A.
12 K factor B	Unit: Pulses per litre. This factor is used for sensor B.
13 Density in kg/m <sup>3</sup>	Density at 20°C
14 Medium temperature	Display of current sensor temperature. Without sensor: 20°C Can be updated via the "►" key
23 Alpha value [kg/m <sup>3</sup> /°C]	Without temperature sensor: No function, with temperature sensor: Factor for density correction
24 Pulse output scaling	0: Original pulses of sensor A. (pulse duration original pulses: 4ms) 1: 1 pulse per change of the right-hand position of V1 (right). 2: 1 pulse per change of the second position ....
25 Pulse duration	Pulse duration. Period duration = 2x pulse duration. [4, 12, 24, 48, 100]
34 Gate time flow display	Period of time which the meter waits before updating the flow display.
35 Attenuation factor	Determination of the mean value via the last 1, 2, 4 or 8 mean values.
36 Total volume meter reset	Resetting the main meter after changing the value from "0" to "1"
45 Max. frequency	Display of the maximum recorded frequency. (Drag indicator function)
46 Not used	
56 Software version	Display of the available software version
123 Current output lower range value	Flow rate of the selected unit which outputs a current of 4mA. Decimal point as for level 4
124 Current output upper range value	Flow rate of the selected unit which outputs a current of 20 mA. Decimal point as for level 4
125 Current simulation	0.00: Off, all other values between 4.00 and 20.00 result in a simulated current output
146 Password	Password can be entered and changed for programming protection. 0000 = off



## Operating Manual Multifunctional Electronics MFE

### 7. Certificates and Approvals

Explosion protection:

The MFE is designed for Zone 1 hazardous areas and is approved in accordance with ATEX and IECEx regulations. It is identified as II2G Ex ib IIC T4.

CE mark:

The measuring system fulfils the legal requirements of the EC Directives 2004/108/EEC including all published revisions or amendments to date. The manufacturer confirms successful device testing and affixing of the CE mark.

### Appendix

#### A. Troubleshooting

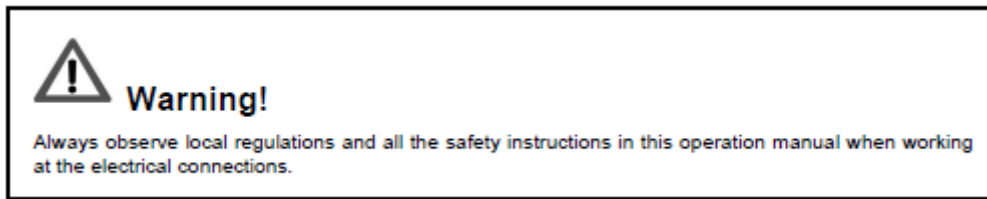

#### General:

If the fault cannot be detected, please contact the service department of Schmidt Mess- und Regeltechnik.

Please contact our service department in the unlikely event of a fault:

Schmidt Mess- und Regeltechnik  
Service  
Frankenhöhe 28  
55288 Spiesheim, Germany  
Phone: +49 6732 919120  
Fax: +49 6732 962442



# Operating Manual Multifunctional Electronics MFE

## B. Battery service life and replacing the battery

The battery service life is approx. 3 years (depending on the operating hours).

When replacing the battery it could take up to 3 minutes after inserting the new battery until the display appears with full contrast.

This physically determined effect is typical of the battery used and has no influence on the later life of the battery.

### Replacing the battery

Exploded drawing of MFE-1 electronics

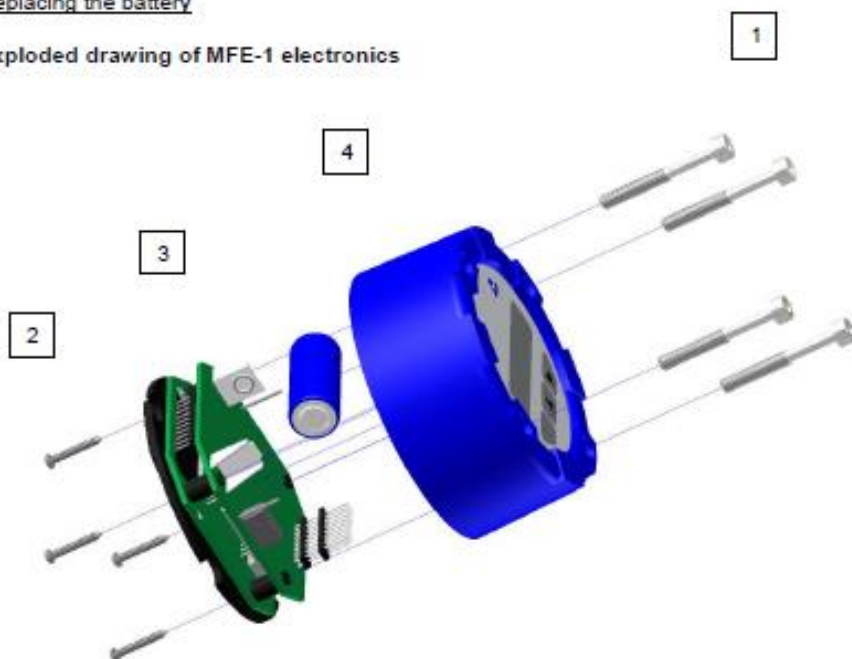

Exploded drawing of MFE-2 electronics

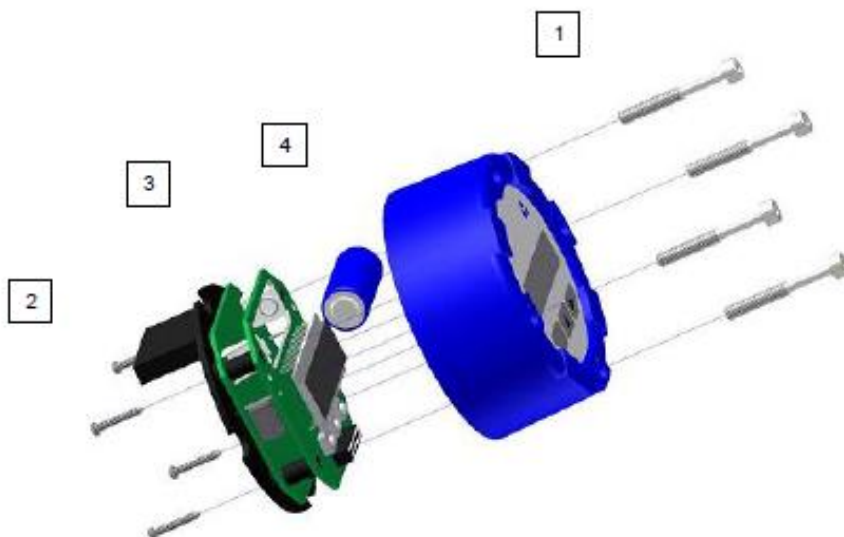

B-EN-MFE-20200203





## Operating Manual Multifunctional Electronics MFE



### Caution!

Only use original batteries from the manufacturer in the hazardous area.

1. Unscrew the hex socket head cap screw (1) at the front of the housing. The electronics housing is released from the oval wheel meter.

**Caution:** MFE-1 electronics is connected to the oval wheel meter. Remove the connector from the electronics.

2. Place the electronics with the display facing downwards on a suitable surface. Unscrew the 4 crosshead screws (2) on the underside of the circuit board.
3. Extract the circuit board (3) from the electronics.
4. Remove the battery (4) from the holder and insert a new battery. Only use original batteries from the manufacturer.

**Pay attention to the correct polarity!**

5. Assembly is carried out in reverse order to disassembly.
6. Make sure the o-ring is positioned correctly when placing the electronics on the oval wheel meter.

**Make sure the display is positioned correctly (check via the film at the front) before installing the 4 crosshead screws.**

**Incorrect installation may damage the display!**

### C. Certificates

#### C.1.1 Explosion Protection Certificate

#### C.1.2 1st Supplement of Explosion Protection Certificate

#### C.2.1 IECEx Certificate of Conformity MFE 1, MFE 2

#### C.2.2 IECEx Certificate of Conformity MFE3

#### C.3 EC-Conformity declaration



## Operating Manual Multifunctional Electronics MFE

### **Important notes!**

Technical changes and errors excepted.

These operating instructions are an integral part of the device and must be kept accessible to the personnel in the immediate vicinity of the device at all times. Persons who install, operate or service this device must read and understand these operating instructions carefully before starting any work. All safety instructions and instructions in this manual must be adhered to. In addition, the local accident prevention regulations and general safety regulations for the area of application of the device as well as all national and international legal regulations and technical standards apply.

All illustrations in this operating manual serve the basic understanding. Photos can be examples of a variant. The illustrations may differ from the actual design of the units. No claims can be deduced from any deviations.

The device has been designed and constructed exclusively for the intended use described here.

Persons installing, operating or maintaining this device must be technically qualified personnel and must comply with the applicable accident prevention regulations.

### **limitations of liability**

All information and instructions in this operating manual have been compiled taking into account the applicable standards and regulations, the state of the art as well as our many years of knowledge and experience. Schmidt Mess- und Regeltechnik accepts no liability for damage due to

- Failure to observe this manual
- Improper use of the device
- Working by untrained personnel with this device
- Unauthorized modifications or technical modifications not approved by the manufacturer
- Use of unauthorized spare parts