



Operation Manual DWU Flow-Switch Type DW-P, DW-N Flow-Meter Type DW-U

1. Delivery and packing

All instruments delivered are ready for operation. Avoid rough handling in order to prevent damage to the sensitive built-in measuring and indication mechanism. There is no security fixing for transportation.

2. Function

Our Flow-Switches and Flow-Meters of the described types work on the principle of dynamic pressure. The flow medium works against a target plate (4), which causes the system to swing against a tension spring (1). A bellows system made from stainless steel (3) seals the indicator and switch equipment against the flowing liquid. Connection between the target plate and the evaluation system is made by a lever arm. A micro-switch (2) is actuated whenever the preselected switch-points are passed. Depending on the type a control-lamp and an indication system for the actual flow will be actuated in addition.

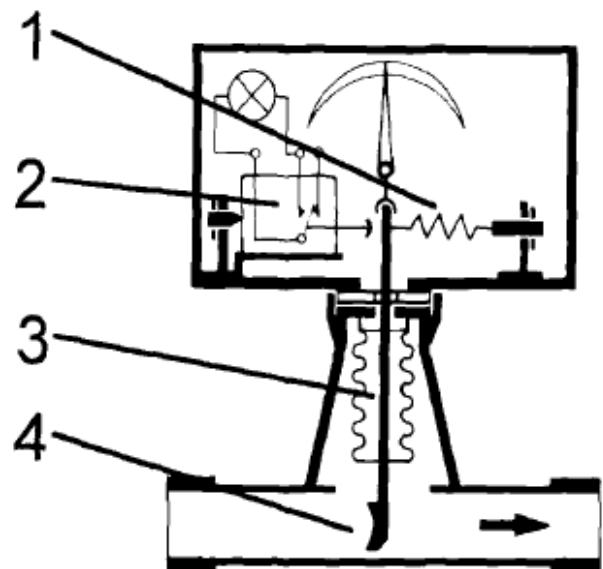

3. Mounting

3.1 Mounting orientation

Our Flow-Switches and Flow-Meters are designed to be installed directly in a pipe system. Make sure that the instruments are installed according to the information on the type plate. The flow direction correlates to the direction of the pipe. Inaccuracy of the instrument will result from incorrect mounting.

3.2. Flow direction

It is essential that the unit is mounted so that flow is as indicated by the arrow on the body. The unit will not operate unless installed correctly in this way.

3.3 Position of mounting

To avoid damages at the measuring system it is especially important to have the biggest possible distance from magnet valves and ball valves. If it is not possible to have a big distance, the valves have to be installed after the instruments. To avoid pressure shocks it is very important to open the valves slowly.

It is advantageous to install the unit in a straight piece of pipe and to choose a place of mounting which has the biggest possible distance from elbows, valves etc.

In order to have an accurate function of the device we recommend a straight length of $10 \times d$ at input side and $5 \times d$ at the output side (d = internal diameter of pipe).



Operation Manual DWU Flow-Switch Type DW-P, DW-N Flow-Meter Type DW-U

3.4 Mounting at the tube

3.4.1 Items with welded socket

The complete flange with screws and sealing is delivered with the instrument. The distance 60mm has to be kept exactly, because this directly effects the calibration of the instrument. Drill a ridgeless hole in the pipe and weld on the socket. Use the enclosed sealing. Please keep the flow direction in consideration during mounting procedure (arrow). The pipe must be free from pollution.

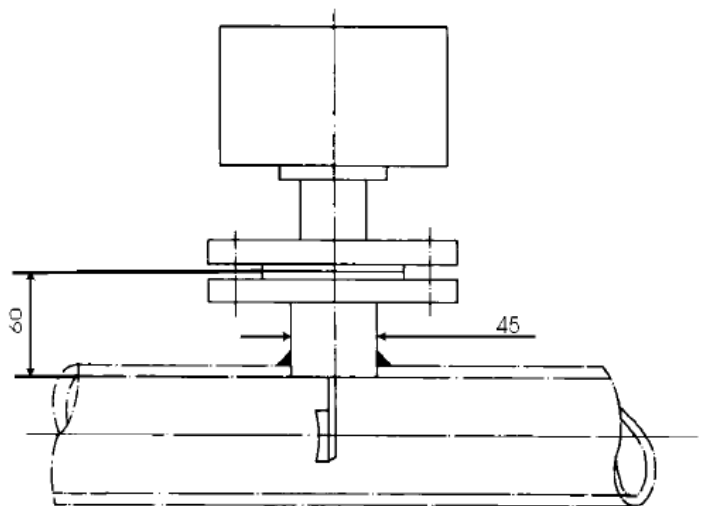

3.4.2 Items with tread connection

We recommend sealing all threads with PTFE sealing tape. Ensure no excess of tape is left protruding into the pipe.

3.4.3 Items with flange connection

An approved flange seal or gasket must be used. Neither this nor the required fixing bolts are included in the delivery.

4. Electrical connection

4.1 Connecting type DW-P

Removing the enclosure to gain access to the three polar connector block. The max. switching performance is up to 230V/5A AC. Please connect the device to ground with help of the designated screw.

Circuit diagram type DW-P

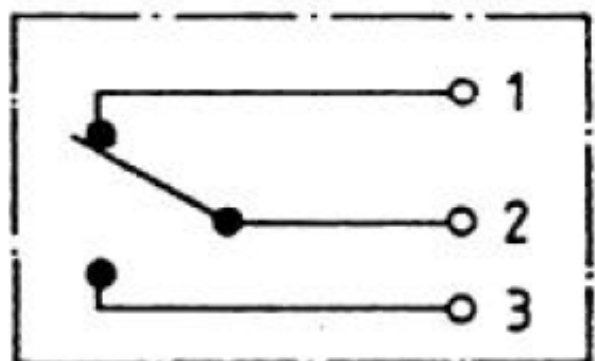



Operation Manual DWU Flow-Switch Type DW-P, DW-N Flow-Meter Type DW-U

4.2 Connecting Type DW-U and DW-N

Removing the enclosure to gain access to the four polar connector block.

Additionally to the micro-switch a control lamp is installed. This lamp is for optical control of switch status of the micro-switch.

The current, which is necessary for the lamp is indicated at the label. The max. switching performance is up to 230V/10A AC.

Please connect the device to ground with help of the screw near cable entry .

Circuit diagram type DW-U/DW-N

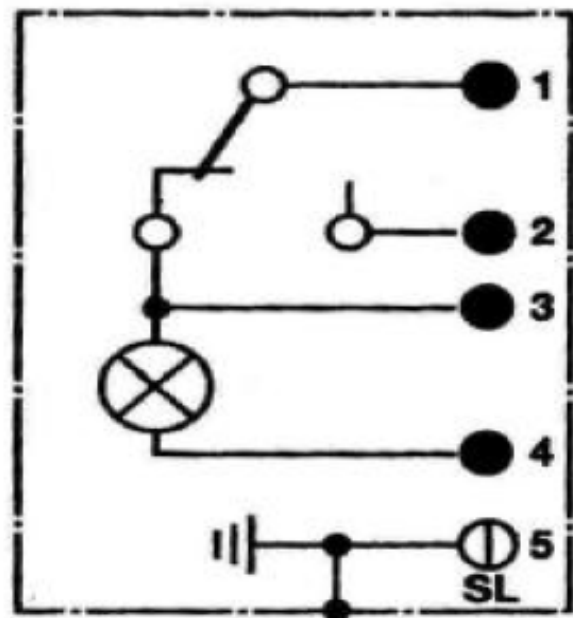

4.3 Connecting Type DW-U-EX and DW-N-EX

The device will be connected at the end of the cable. The connection must be done in a area which is not endangered by explosion (use EX cable gland), or in a special EX connection enclosure.

The max. switching performance is up to 230V/5A AC.

Circuit diagram type DWU-EX/DW-N-EX

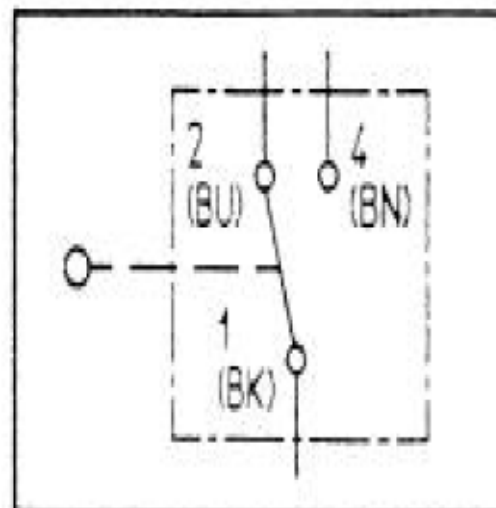



Operation Manual DWU Flow-Switch Type DW-P, DW-N Flow-Meter Type DW-U

5. Calibration dates

Calibration dates, type of device and serial number are indicated at the label. Changes of medium, pressure and position of mounting will influence accuracy.

6. Switch-point

Type DW-P

The switchpoint is fixed by the manufacturer according to customer's request. Changes can only be made by the supplier.

Type DW-N, DW-N-EX

Alterations of the switchpoint can be made by the customer within the limits indicated on the scale.

Type DW-U, DW-U-EX

Alterations of the switchpoint can be made by the customer within the limits indicated on the scale.

The actual flow is indicated at front side of the unit.

7. Maintenance

The mentioned HSW instruments are almost maintenance-free. In case of mal-function first of all check the pipe system for calcification or other obstruction.

For cleaning do not use sharp-edged tools. Damaged instruments can only be repaired in our factory, because they have to be re-calibrated.

Damaged items should send back to the manufacturer because it is only there possible to do the re-calibration which is necessary.

Unscrewing screws, changing tension spring or bellow system changes calibration and will invalidate the guarantee.

8. Further requirements

Following measurements always must be applied together with valid technical rules.



Operation Manual DWU Flow-Switch Type DW-P, DW-N Flow-Meter Type DW-U

8.1 Description of function

The DW-U-EX type device is a combination out of a flow switch and a flow meter with analogue display of flow and a flow-switch with adjustable switchpoint. The DW-N-EX type device is a flow-switch with adjustable switch point but without additional indication of flow. The DW-U and DW-N device is also available with gold plated contacts for intrinsic safe circuits without EX switch. Additionally a version with two independent adjustable switches is available.

The devices can be used as follows:

- a. In Zone 2 (Gas-Ex, Category 3G) in the Explosion group IIA und IIB
- b. In Zone 22 (Dust-Ex, Category 3D) at dust with minimum ignition energy > 3 mJ
- c. In Zone 1 (Gas-Ex, Category 2 G) in the Explosion group IIA und IIC
- d. In Zone 21 (Dust-Ex, Category 2D) at dust with minimum ignition energy > 3 mJ
- e. Usually there is no zone within the measuring tube. Here Zone 1 may appear as maximum.

The qualification regarding surface temperature is T4; for all gases, dusts, haze with an ignition temperature > 125°C the mentioned devices are no ignition source.

At the dust EX category the reference temperature is 110°C. Further decisions concerning the safety distance from glow temperature are up to the operator.

8.2 Assembly units

The devices Type DW-U and DW-N consist out of following units:

Z	Description	Valuation of ignition risk	Remarks
1	Lower part with target plate, metal bellow, flanges	HSW included	
2	Upper part with mechanics and indication	HSW included	
3	Switch	Company Stahl	Manufacturers explanation/BA
4	Switch as simple apparatus	arbitrary	500 Volt to Earth



Operation Manual DWU Flow-Switch Type DW-P, DW-N Flow-Meter Type DW-U

8.3 Start operation, Installation

The devices have to be installed in an overriding facility. Depending from IP protection grad the time of cleaning the device (dust deposit) has to be defined. It has to be taken under consideration that only the device ignition protection class is installed which corresponds to the relating zone. During the installation the valid national regulations have to be observed (for example EN 60079-14).

Further important facts:

- Only experts may put the devices into operation.
- Only operation of devices with complete mounted and intact enclosure is permissible.
- The potential balance will be installed with its own screw at the metallic pipe system. National regulation has to be taken under consideration.
- The devices have to be protected against liquids and pollution.
- The device mainly consists from metal and plastic. External impacts should be avoided.
- The device only may be exposed to low vibrations. Please ask the supplier if you are not sure.

8.4 Range of use

The devices only are approved for appropriate use and as directed. If it is acted against these rules each responsibility of the produces as well as any claim on guaranty is expired!

- Only equipment parts which fulfil all requests of the European guidelines and of the national legislation are allowed to be used in explosion endangered areas.
- The area conditions stated in the operation manual must be strictly observed.
- The devices are suitable for the use in general industry air. If there are any aggressive substances in the air the manufacturer has to be consulted absolutely.
- Stacked pieces, e.g. due to corrosion, are not allowed to be removed violently in an EX-atmosphere.
- Protection measures against lightnings have to be ensured by the supplier.

8.5 Maintenance, service

Definition of terms to IEC 60079-17:

Service and repair: a combination of all occupations which are carried out in order to keep an object in a condition or in order to repair it, which meets the requests of the corresponding specification and which guarantees the execution of the required functions.

Inspection: An occupation which includes the careful examination of an object in order to get a reliable statement about the condition of this object. This occupation is carried out without dismantling or, if necessary, with partly dismantling, completed by measures as e.g. measuring.

Visual examination: A visual examination is an examination to remark viewable defects, e.g. missing screws, without the use of access installations or tools.



Operation Manual DWU Flow-Switch Type DW-P, DW-N Flow-Meter Type DW-U

Proximity examination: An examination to identify such defects as e.g. loose screws which are only discernible by using access installations like a step or tools, additionally to the aspects of the visual examination. A cabinet usually doesn't need to be opened or the voltage of the operating lotion doesn't need to be switched off.

Detailed examination: An examination additionally to the aspects of the proximity examination in order to remark such defects as e.g. loose connections which are only discernible by opening cabinets and/or, if necessary, using tools and examination installations.

- Maintenance measures are to be executed only by qualified persons.
- The exchange of components is only allowed to occur with original spare parts which are also made accessible for the use in the ex-area, this is also valid for possible use of lubrication and assistance materials.
- The devices are to be cleaned and maintained regularly in the ex-area. The intervals are determined by the operator in accordance with the environmental claims.
- After the service and/or maintenance all removed barriers and advices must be attached in the initial position.

	Activity	Visual examination Daily	Visual examination monthly	Proximity examination every 3 months or 2000 h	Detailed examination every 6 months or 4000 h
1	Visual control of the devices, disposal of dust		•		
2	Device in general			•	
3	Examination of the plant for leaking				•

Special measures:

- Observance of the operation manual of the delivered construction groups, realization of the manufacturer's conditions

8.6 Elimination of faults

It's not allowed to make changes on devices which are operated in explosion endangered areas. Only specialists who are authorized for this case are allowed to carry out repairs on the device.

8.7 Waste disposal

The disposal of packaging and used pieces has to take place in accordance with the country's regulations where the device is installed.